

Gražina Karaneckienė

SAULUTĖ

Pratybų sąsiuvinis 1 klasei

1 DALIS



Wydanie pierwsze



Puńsk 2011
Wydawnictwo „Aušra” Sp. z o.o.
www.punskas.pl

SAULUTĖ. Pratybų sąsiuvinis 1 klasei, 1 dalis.

Zeszyt ćwiczeń do podręcznika *Saulutė* do kształcenia zintegrowanego dla kl. 1, część 1.

Opracowanie

Grażyna Korzeniecka

Ilustracje i okładka

Eglė Valiūtė

Zdjęcia

Sygit Birgiel

Redaktor

Nijola Birgiel

Redaktor techniczny

Sygit Birgiel

Korekta

Biruta Olów

Podręcznik dopuszczony do użytku szkolnego przez ministra właściwego do spraw oświaty i wychowania i wpisany do wykazu podręczników przeznaczonych do kształcenia ogólnego dla mniejszości narodowych i etnicznych oraz społeczności posługującej się językiem regionalnym do edukacji wczesnoszkolnej w języku litewskim, na podstawie opinii rzeczoznawców:

prof. dr. hab. Mieczysława Jackiewicza, mgr. Algisa Uzdili, dr Any Romančuk.

Etap edukacyjny: I.

Typ szkoły: szkoła podstawowa.

Rok dopuszczenia 2010.

Nr ewidencyjny w wykazie: 301/1/2010.

Podręcznik jest finansowany przez Ministerstwo Edukacji Narodowej



Nupiešk,
nusalvink



Parašyk



Perskaityk



Pagalvok,
papasakok



Muzikinė
užduotis



Dailės
darbelis

ISBN 978-83-60625-44-6

© Wydawnictwo „Aušra” Sp. z o.o.

Wydawnictwo „Aušra” Sp. z o.o., ul. A. Mickiewicza 23, 16-515 Puńsk

Arkuszy drukarskich 12,5. Wydanie I

Skład, łamanie, druk i oprawa Wydawnictwo „Aušra”

w w.w.punskas.pl



1. Baik piešti mokyklą. Piešinį gali papildyti taip, kad mokykla tau atrodytų dar jaunesnė.

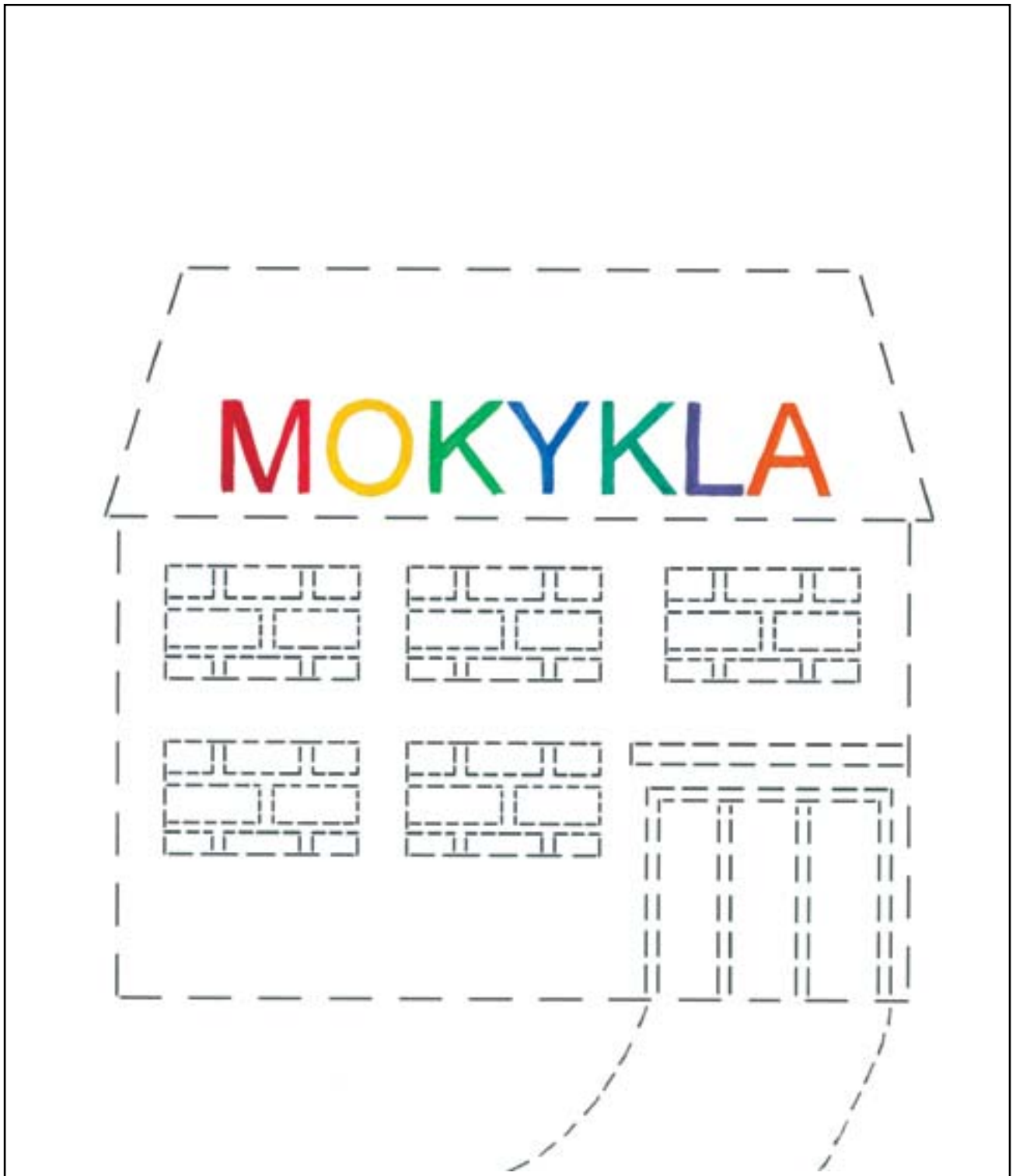

MOKYKLA



2. Nuspalvink raides tokiomis pačiomis spalvomis, kaip nurodyta paveikslėlyje. Jeigu moki, perskaityk žodį.



1. Štai tavo draugai – „Saulutės” pirmokai. Susipažink su jais. Pabandyk perskaityti jų vardus.

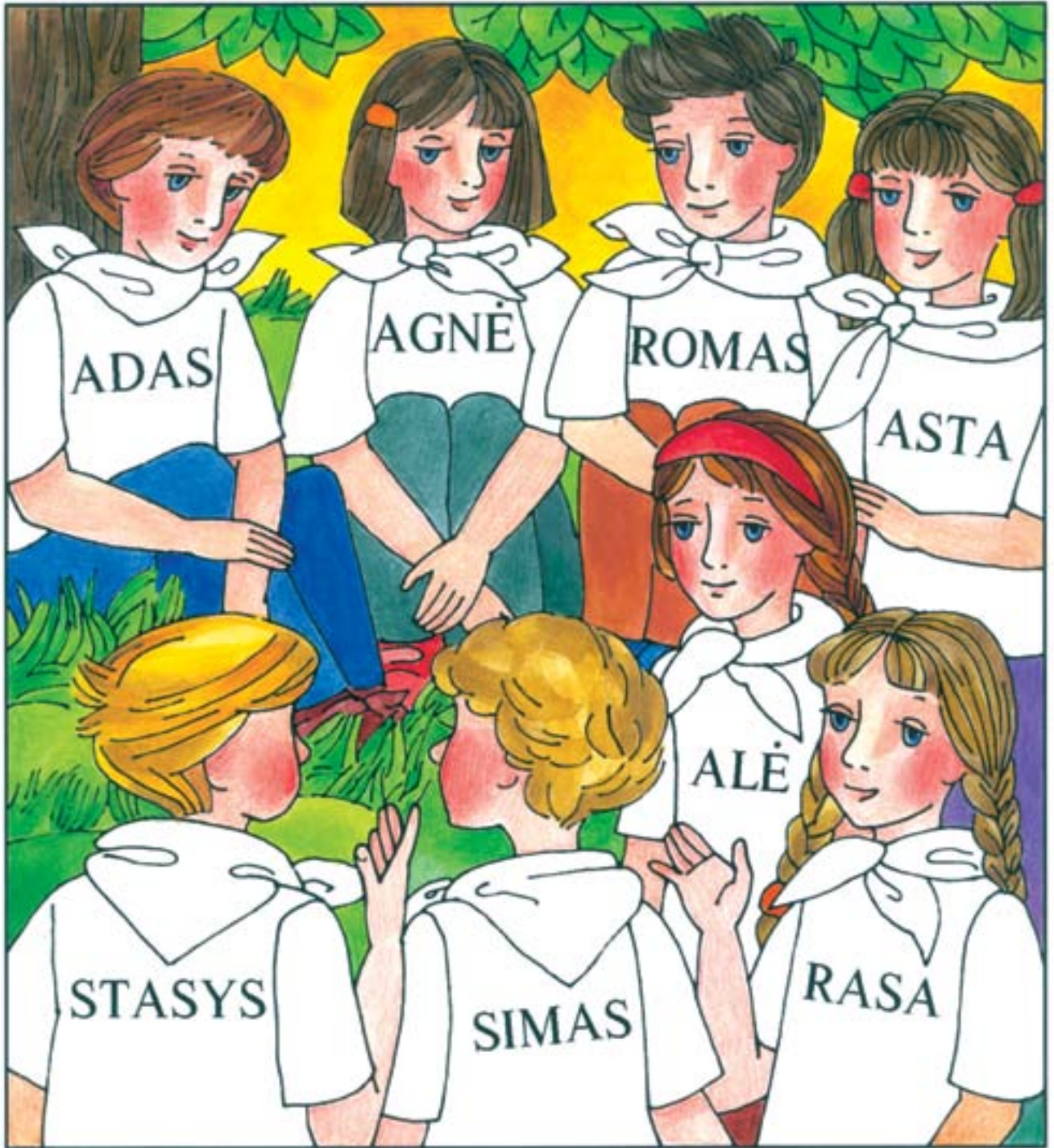

2. Kurių vaikų vardai prasideda ir baigiasi ta pačia raide? Nupiešk ant jų marškinėlių po .



3. Vienodomis spalvomis nuspalvink marškinėlius tų vaikų, kurių vardai prasideda ta pačia raide.



4. Vienodomis spalvomis nuspalvink skareles tų vaikų, kurių vardai baigiasi ta pačia raide.



5. Nupiešk savo vizitinę kortelę. Kam ji reikalinga?

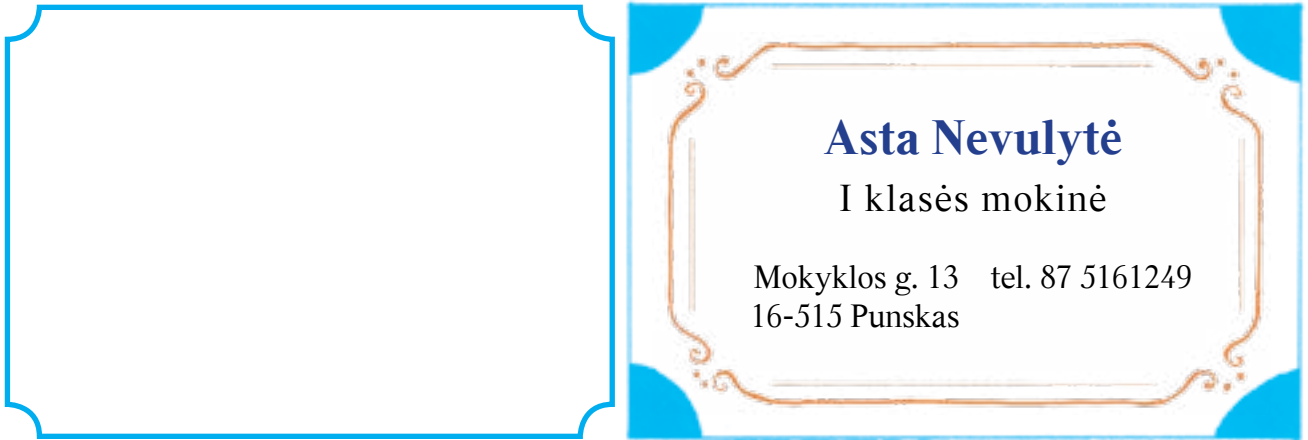

6. Nupiešk savo draugo portretą. Jeigu moki, parašyk jo vardą.

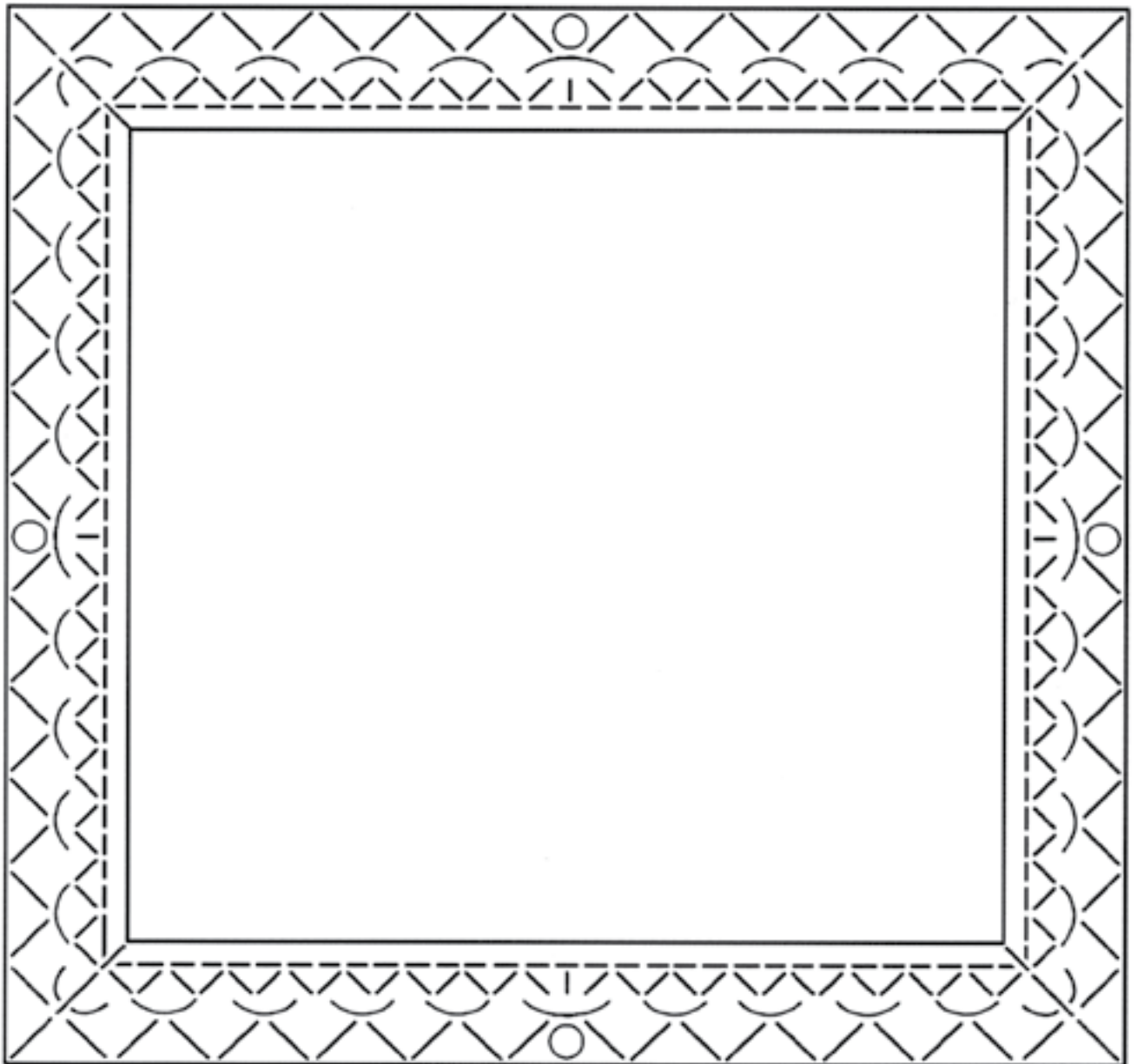

7. Baik piešti paveikslo rėmus.



1. Padėk zuikučiui nukeliauti į mokyklą, aplenkiant visas kliūtis.



2. Kokie žodžiai pasislėpė gėlytėse? Kada reikia juos sakyti?



3. Baik piešti žiedlapius. Parink tinkamas spalvas.

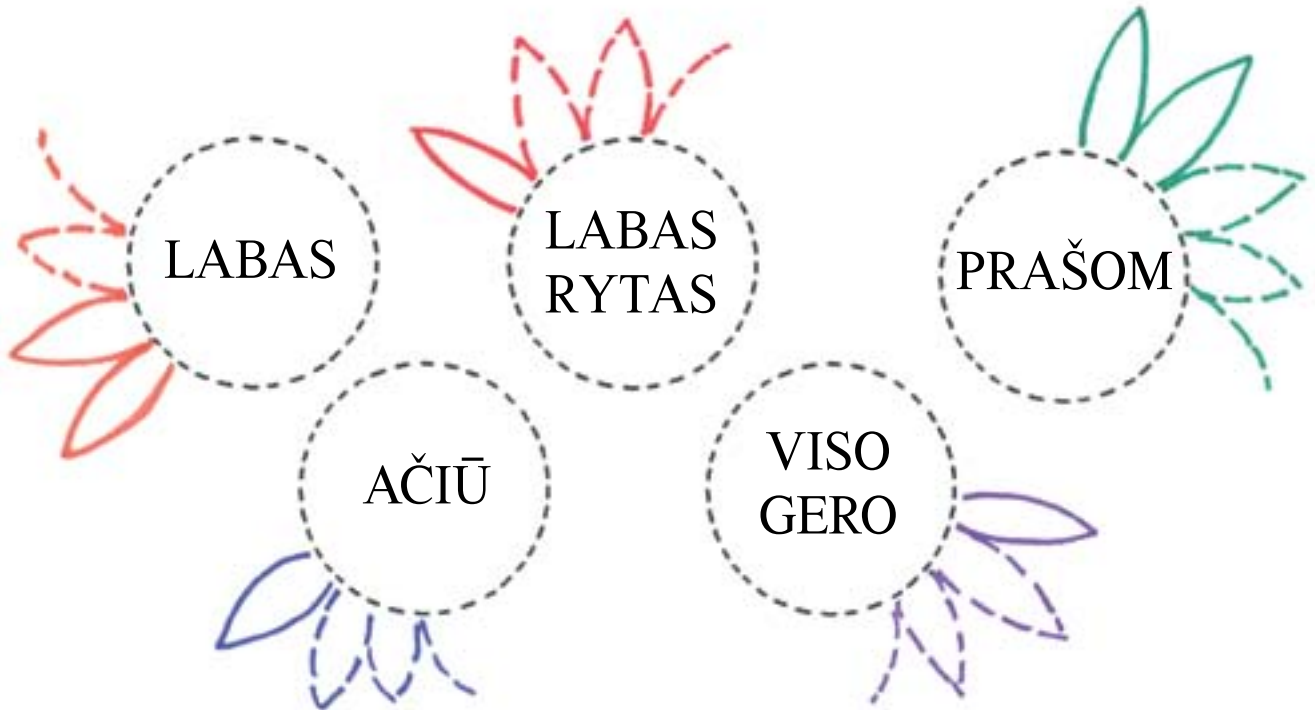

4. Padėk varlytei nušokuoti į jos suolą.





5. Kuriame suole sėdi ASTA, kuriame – TOMAS, o kuriame ONUTĖ? Nubrėšk vaikų kelias nurodytomis spalvomis.

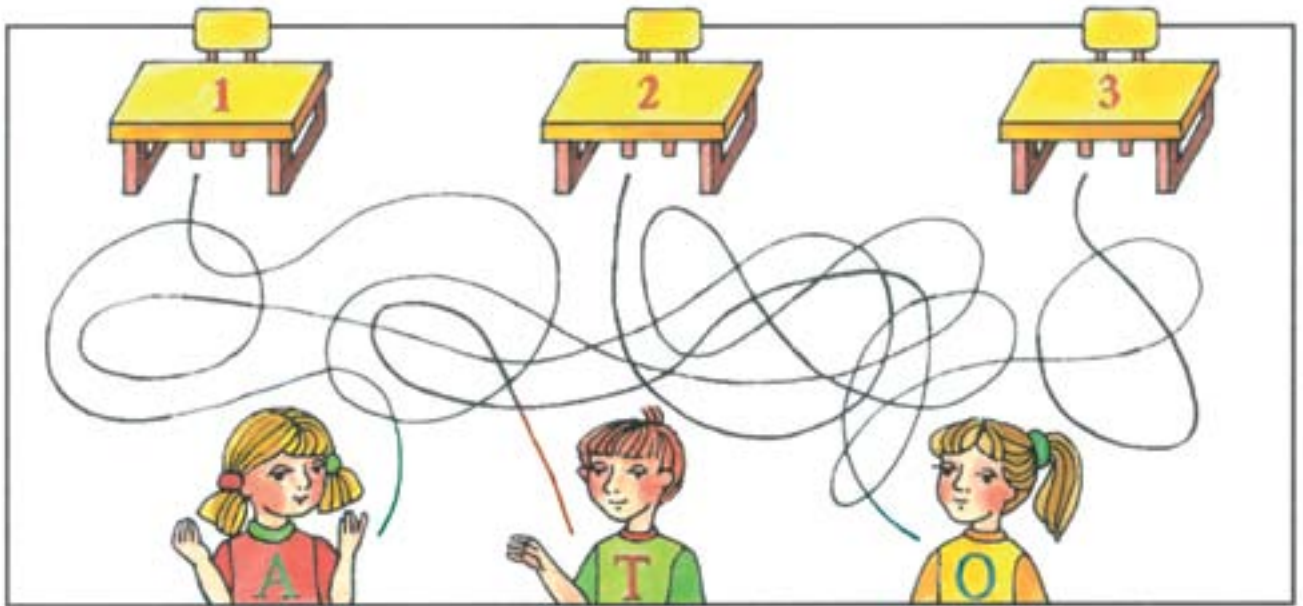

6. Kuris mokinys išaugs tiesia nugara? Kodėl? Nuspalvink paveikslėlį, kuris rodo, kaip taisyklingai sėdėti suole.



7. Sėdėk tiesiai ir piešk.

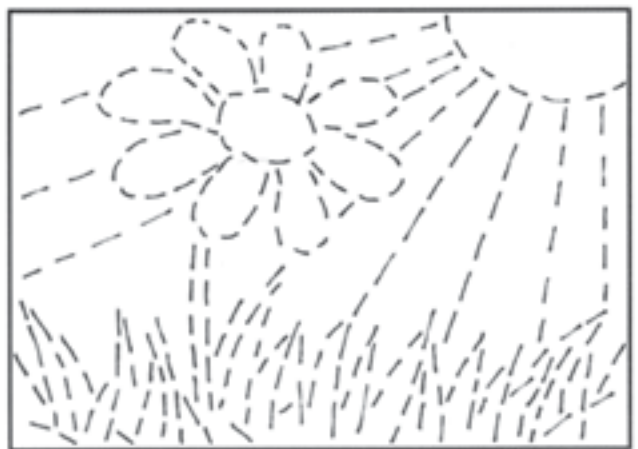
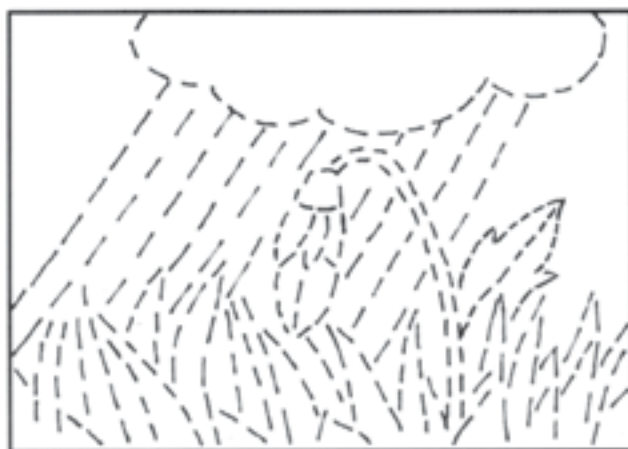



1. Pasakyk daiktų pavadinimus skiemenimis. Nuspalvink tiek langelių, kiek žodyje yra skiemenų.



2. Pabaik ir nuspalvink piešinius.

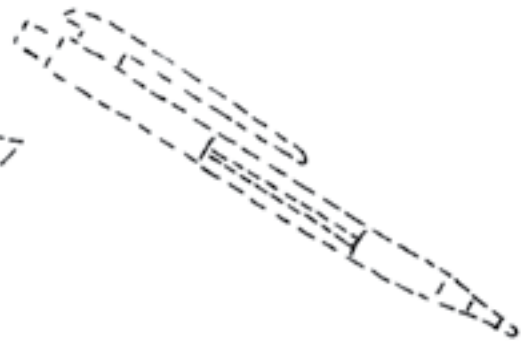
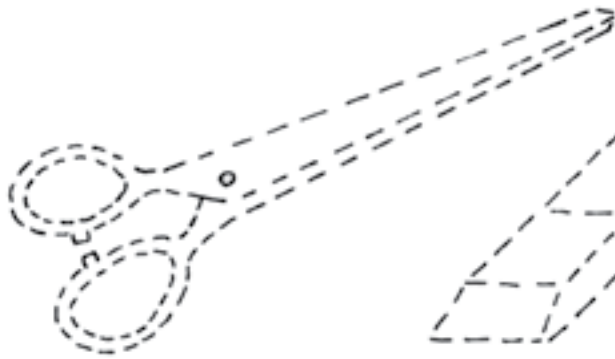

--	--	--	--

--	--	--	--

--	--	--



3. Nupiešk tiek skrituliukų, kiek skiemenų yra paveikslėlių pavadinimuose.

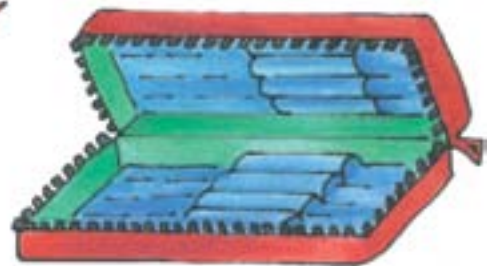
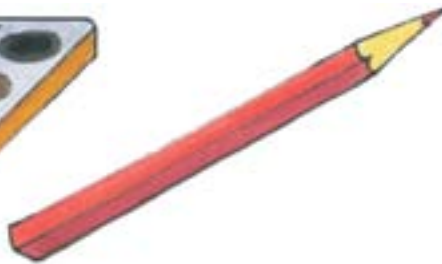

--

--

--



4. Pažymėk ženklų * mokinį, kuris taisyklingai neša kuprinę.



5. Apvedžiok ir nuspalvink spalvotus pieštukus.





1. Sujunk tokius pačius daiktus.



2. Baik piešti ir nuspalvink paveikslėlių.

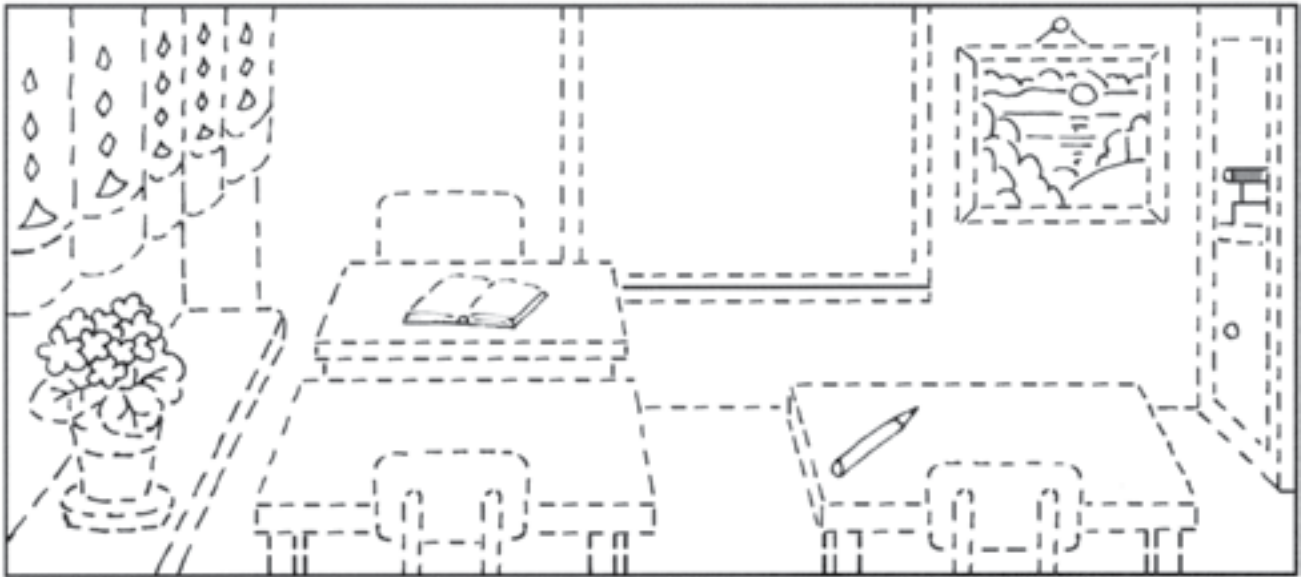

3. Ką mokiniai veikia klasėje? Pasakyk veiksmų pavadinimus ir nuspalvink tiek langelių, kiek žodyje yra skiemenų.



--	--	--	--



--	--	--	--



--	--	--	--



--	--	--	--



4. Nuspalvink tiek juostelių, kiek sakinyje yra žodžių.

Tomas ėjo iš klasės.

--	--	--	--	--	--

Kur bėga Rasa?

--	--	--	--	--	--



1. Pasakyk skiemenimis gėlių pavadinimus. Nupiešk tiek gėlių, kiek žodyje yra skiemenų.

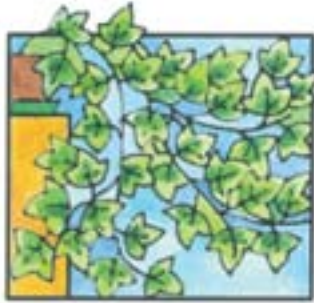
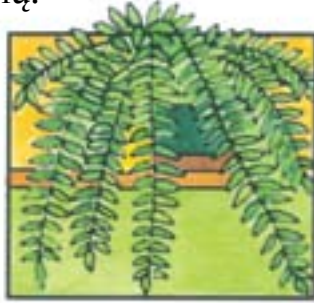

2. Kur auga šios gėlės? Nuspalvink tiek langelių, kiek gėlių pavadinimuose yra skiemenų.



3. Papuošk vazes.

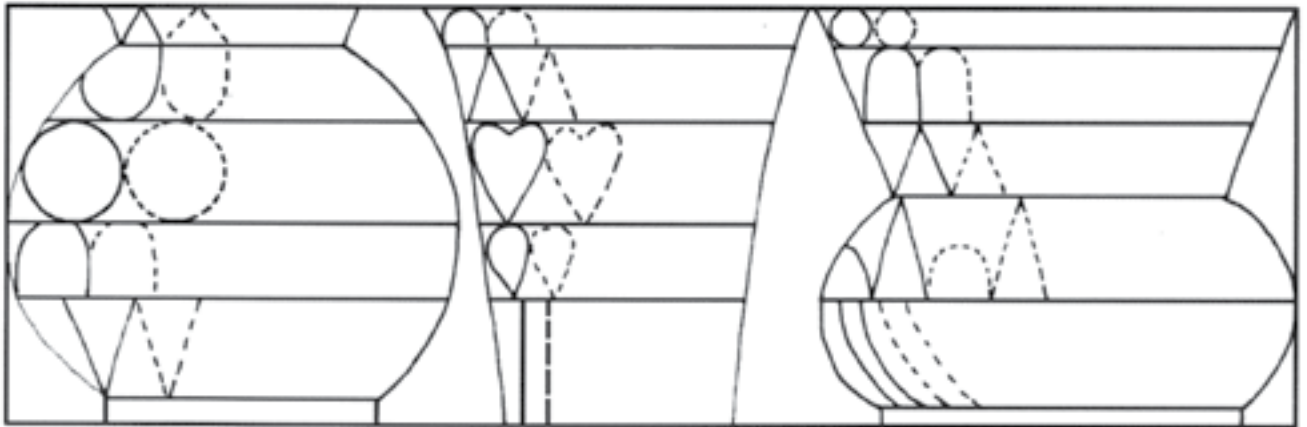

4. Kuri gėlė išsiskleis iš pumpuro? Sujunk ją su pumpuru. Nuspalvink visas gėles.





1. Rask 5 skirtumus. Skirtingas vietas nuspalvink.



2. Daiktus, kurių pavadinimuose girdi skiemenį **dė**, sudėk į dėžę, o dalykus, kuriuose girdi **ka**, sumesk į karučius.

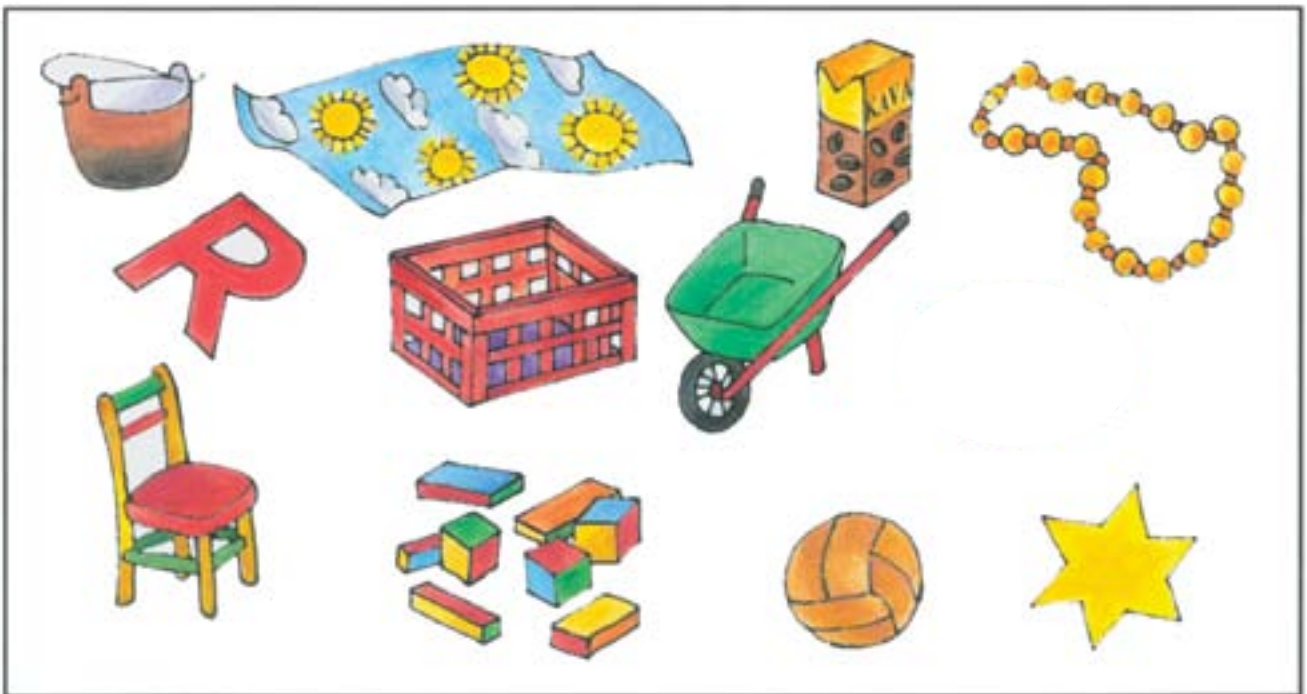

3. Nuspalvink tiek langelių, kiek daiktų pavadinimuose yra garsų.



--	--	--	--	--

--	--	--	--	--

--	--	--	--	--

--	--	--	--	--



1. Pasakyk paveikslėliuose pavaizduotų mokyklos patalpų pavadinimus skiemėmis. Nupiešk tiek skrituliukų, kiek žodžiuose girdi skiemėnų.



2. Uždenk mokyklos stogą. Čerpes nuspalvink įvairiomis spalvomis.

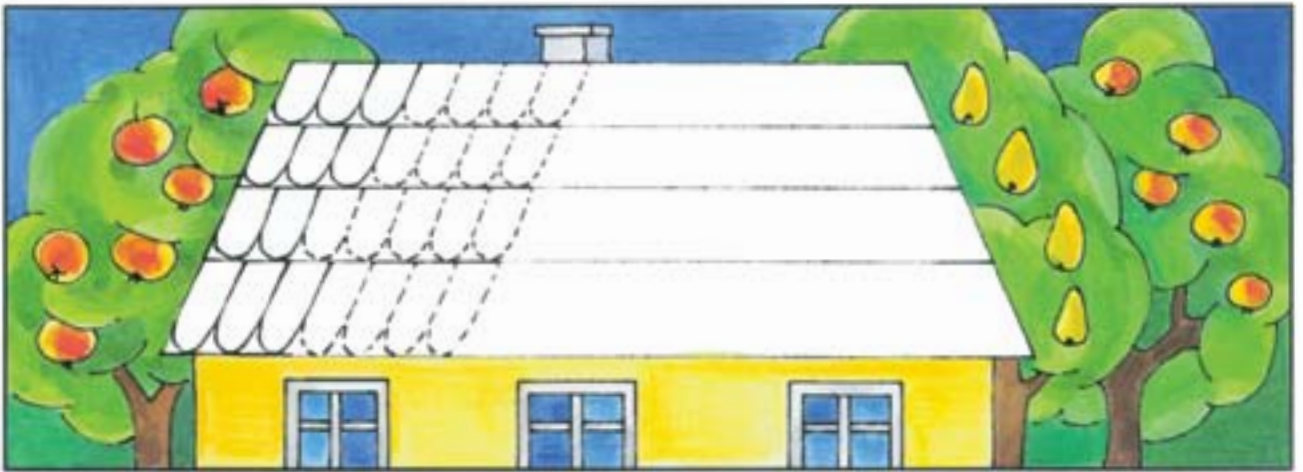

3. Sujunk paveikslėlius, kurių pavadinimai prasideda tuo pačiu garsu.



4. Nupiešk širdeles. Kiekvieną nuspalvink kita spalva.





1. Ko trūksta autobusams? Nupiešk.



2. Kokių spalvų autobusus matai paveikslėlyje? Tokiomis pačiomis spalvomis nuspalvink kiekvieno autobuso kelią į mokyklą.

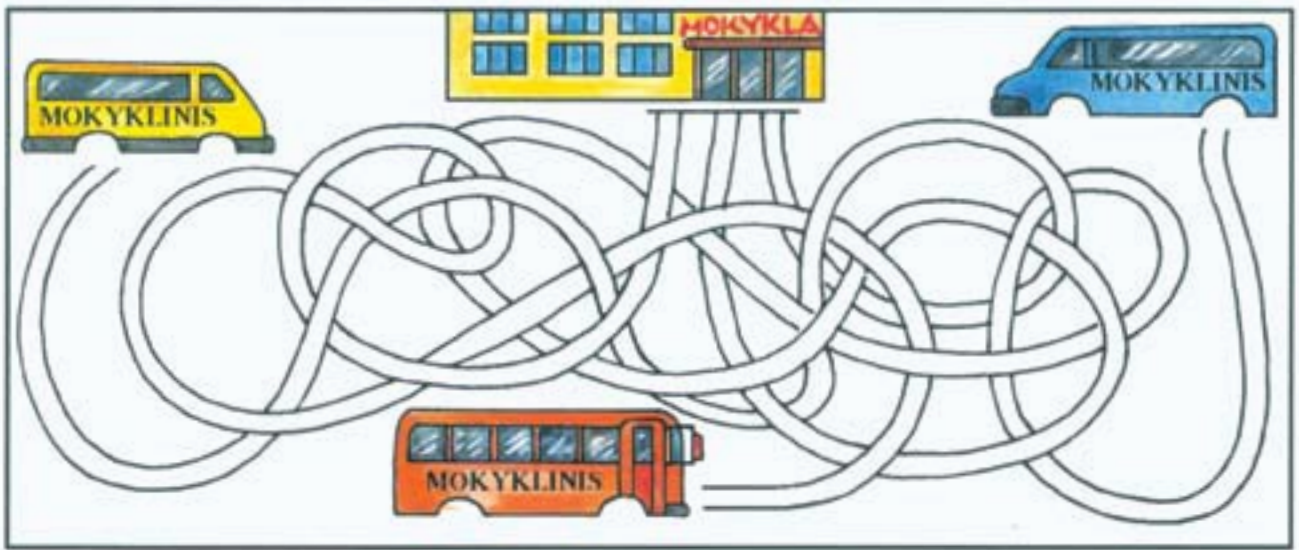

3. Nupiešk, kas kaip keliauja.

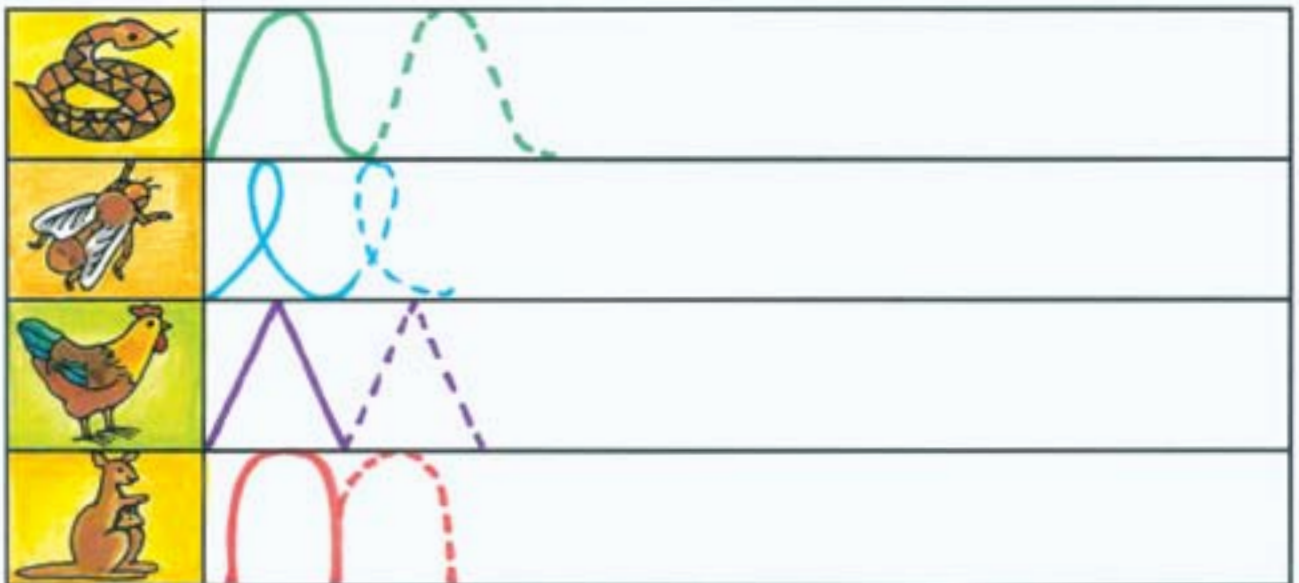

4. Sujunk paveikslėlius, kurių pavadinimai baigiasi tuo pačiu garsu.





1. Pakartok spalvų pavadinimus. Nuspalvink nurodytomis spalvomis.

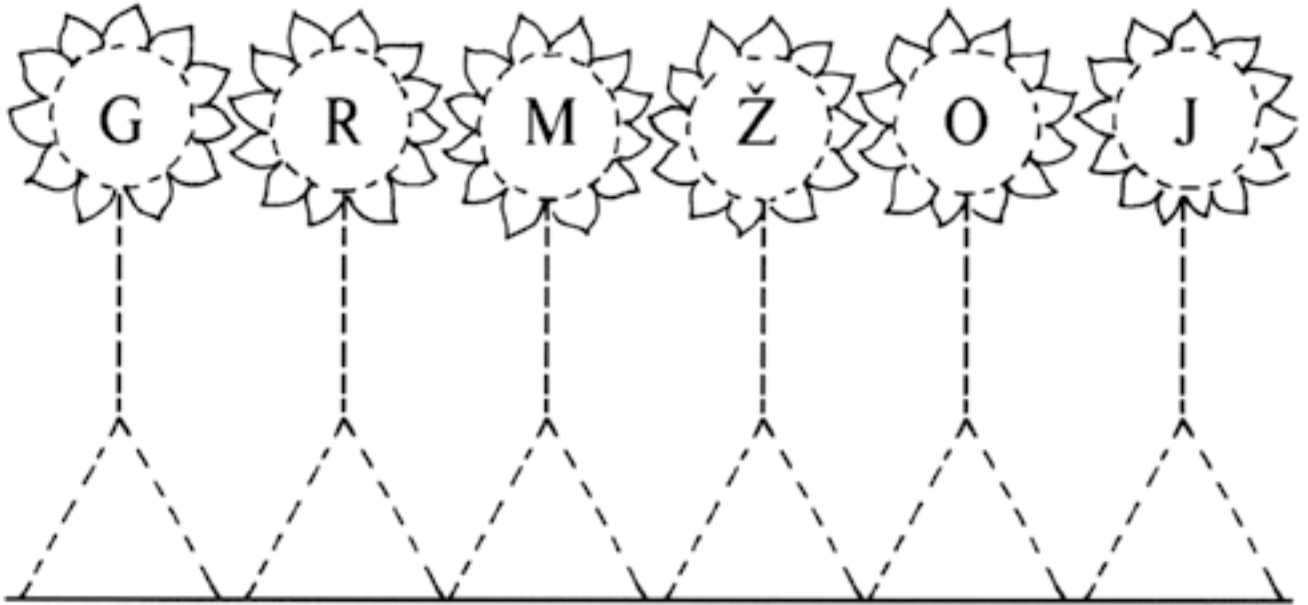

2. Kokių spalvų yra šviesoforo lempos? Baik jas piešti ir nuspalvink.

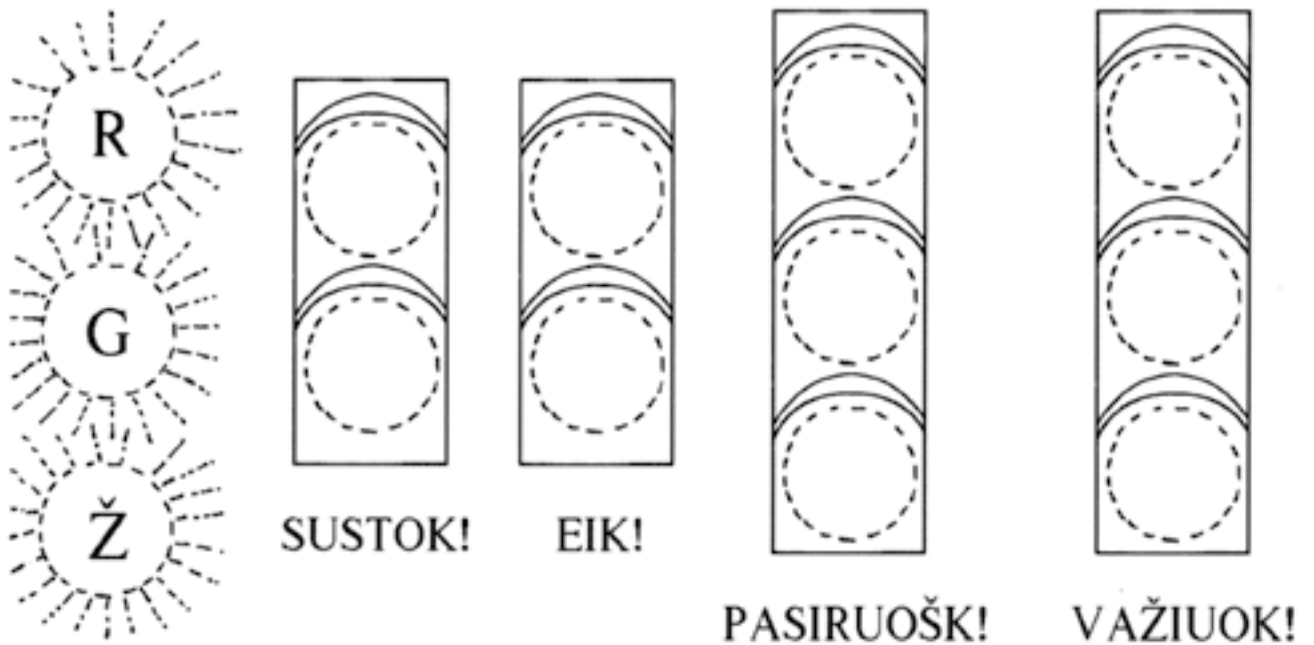

3. Nupiešk, kokius ženklus paliko smėlyje mašinų padangos.

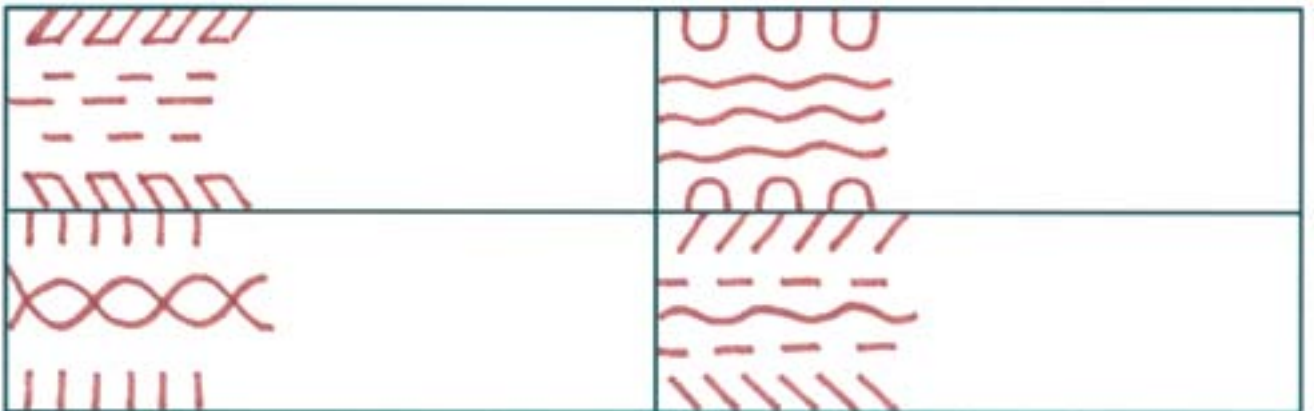



1. Pažymėk raides, kurias jau pažįsti. Nupiešk paveikslėlį raidei, kuri tau labiausiai patinka. Nuspalvink laivelį.

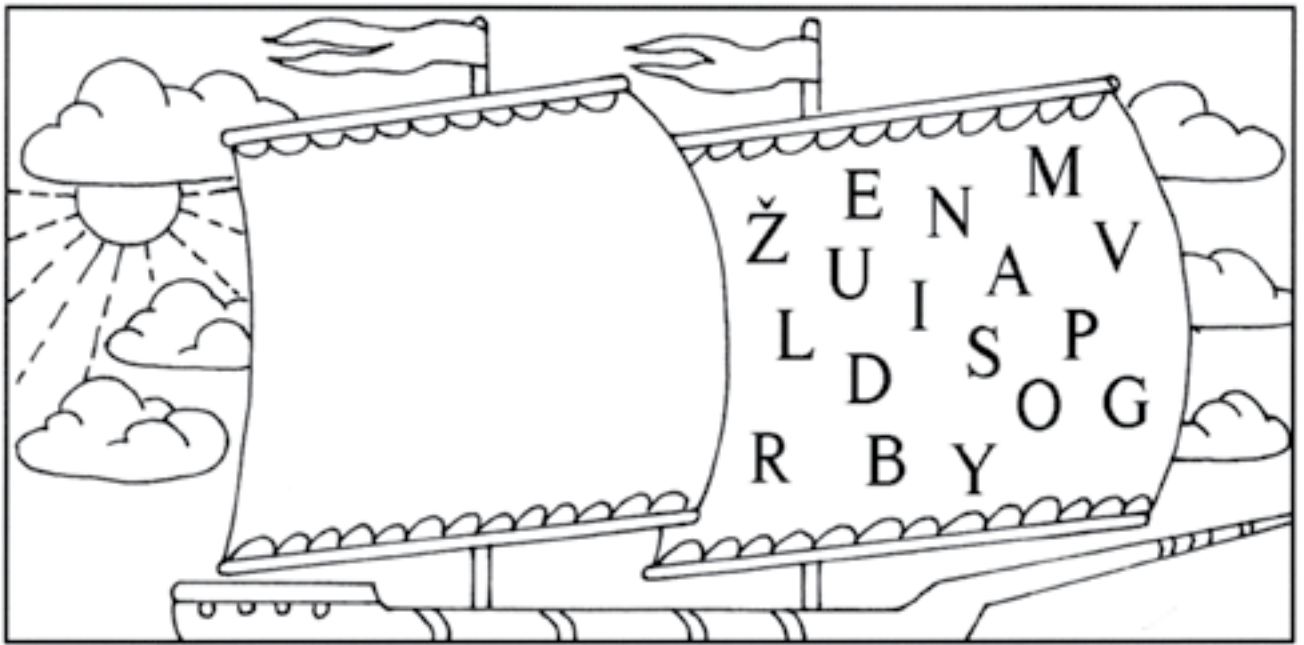

2. Pirmame namelyje gyvena dviskiemeniai žodžiai, antrame – triskiemeniai, trečiame – keturskiemeniai. Sujunk paveikslėlius su atitinkamais nameliais.



3. Sujunk, kaip pradėta.

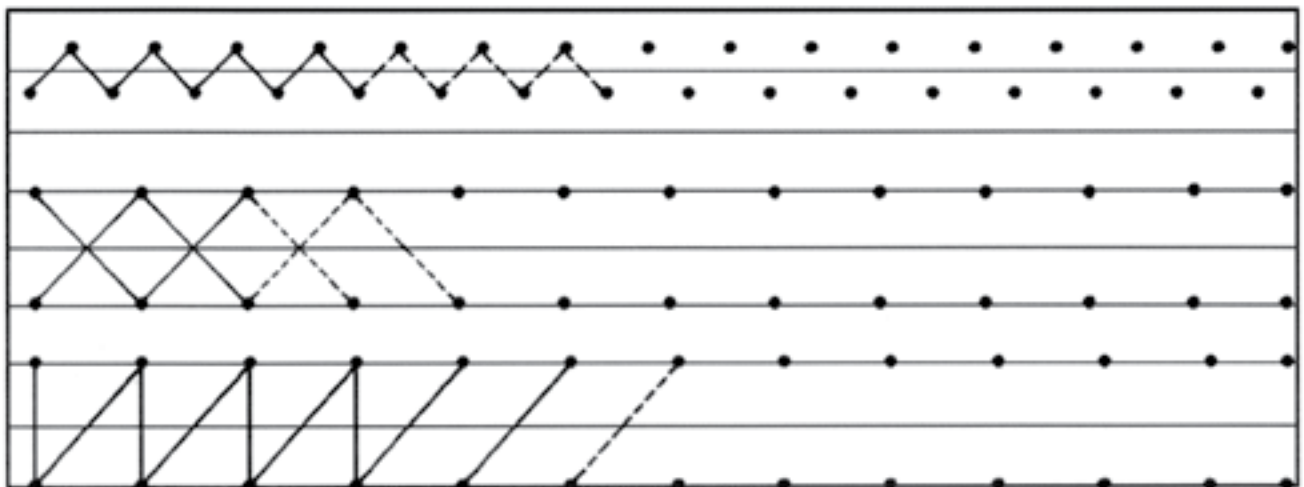



1. Sujunk tokius pačius didelius ir mažus daiktus.



2. Nuspalvink tuos daiktus, kurių pavadinimai prasideda garsu **a**.



3. Atskirk didžiąsias raides nuo mažųjų. Mažąsias raides paryškink žaliai, o didžiąsias – mėlynai.

a A o O m e E s S



4. Nupiešk žmogelius.

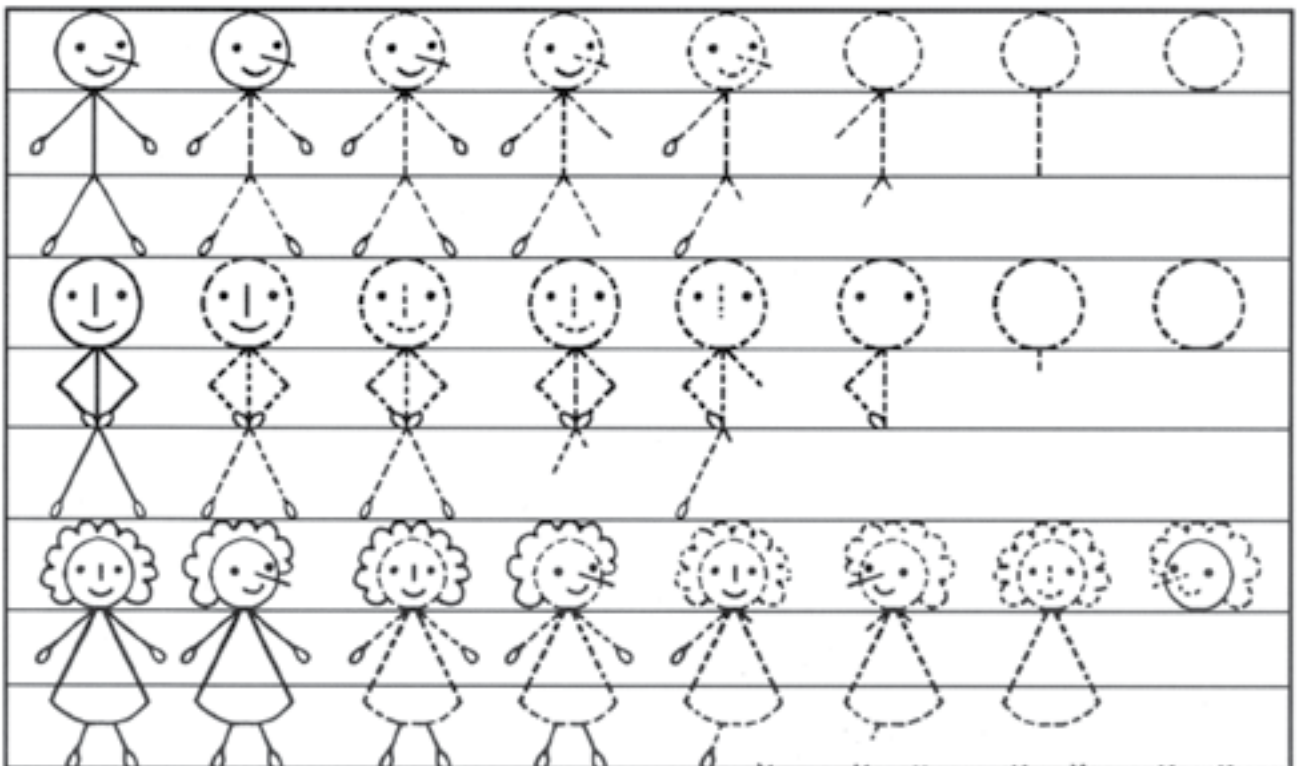

a A



1. Nuspalvink piešinio dalis pagal pateiktą kodą.



2. Nuspalvink langelį, žymintį garsą a.

a A

--	--	--	--



- juoda
- ▼ mėlyna
- ◻ oranžinė
- geltona



3. Parašyk raides.

a A

a A



4. Pavadinink paveikslėlius. Pasakyk pavadinimus skiemenimis ir garsais. Įrašyk a.

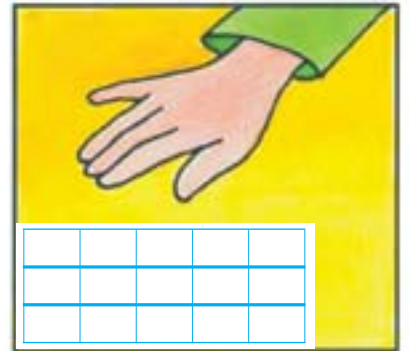
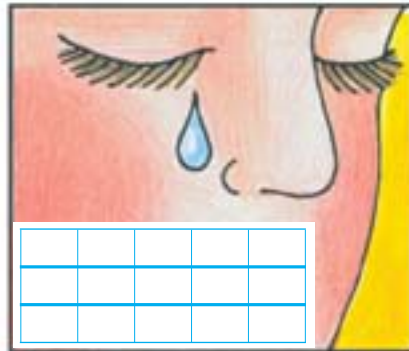
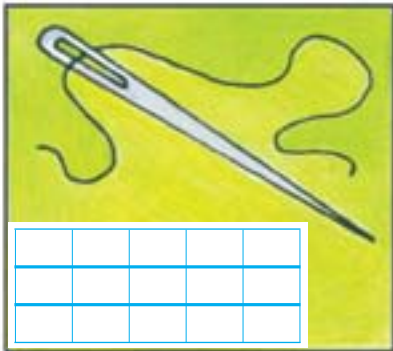

5. Pasakyk vaikų vardus skiemenimis ir garsais. Įrašyk a ir A.

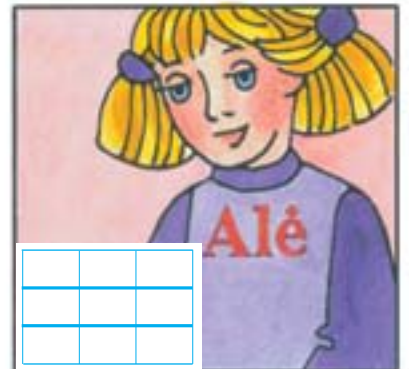
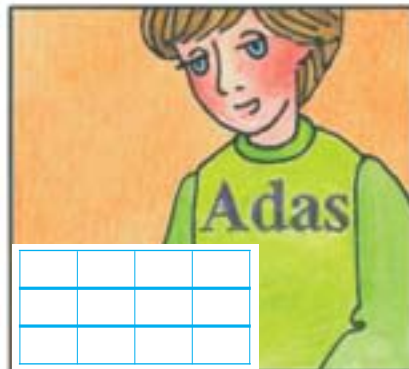
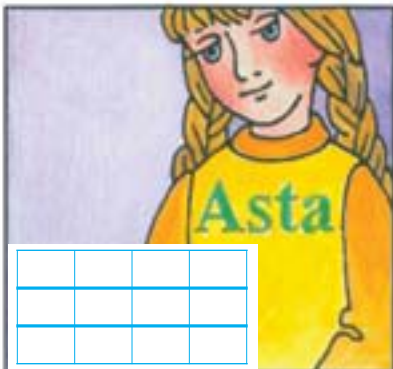



1. Pasakyk daiktų pavadinimus skiemenimis ir garsais. Nuspalvink langelius, žyminčius garsą **a**.

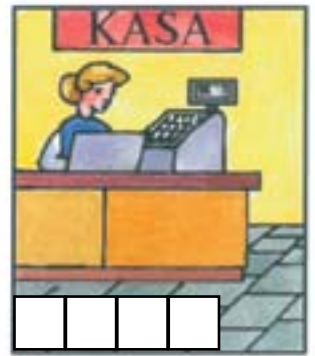
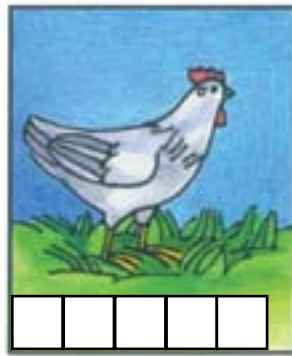
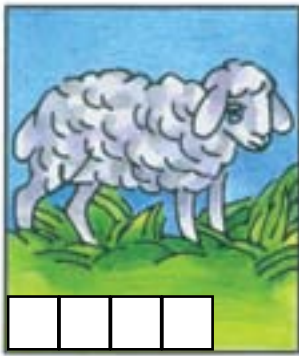

2. Nuspalvink lapelius su žodžiais, kuriuose yra ir **a**, ir **A**.

Antanas

arbata

Agurkiai



3. Ritmiškai pasakyk skaičiuotę.



4. Kaladėles su **a** nuspalvink žaliai, o kaladėlę su **A** – mėlynai.

A da ta

pa da ta,



Po pa du

va da ta.

ta ti



5. Papuošk indus pagal pavyzdį.

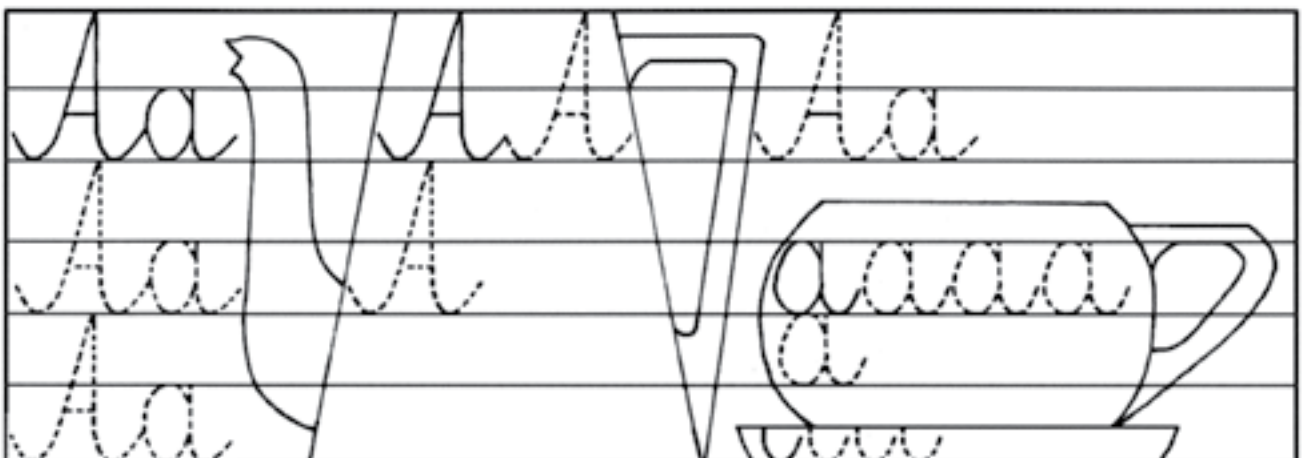



1. Kam ko trūksta? Nupiešk.



2. Nuspalvink tik pasakos „Dangus griūva” veikėjus.

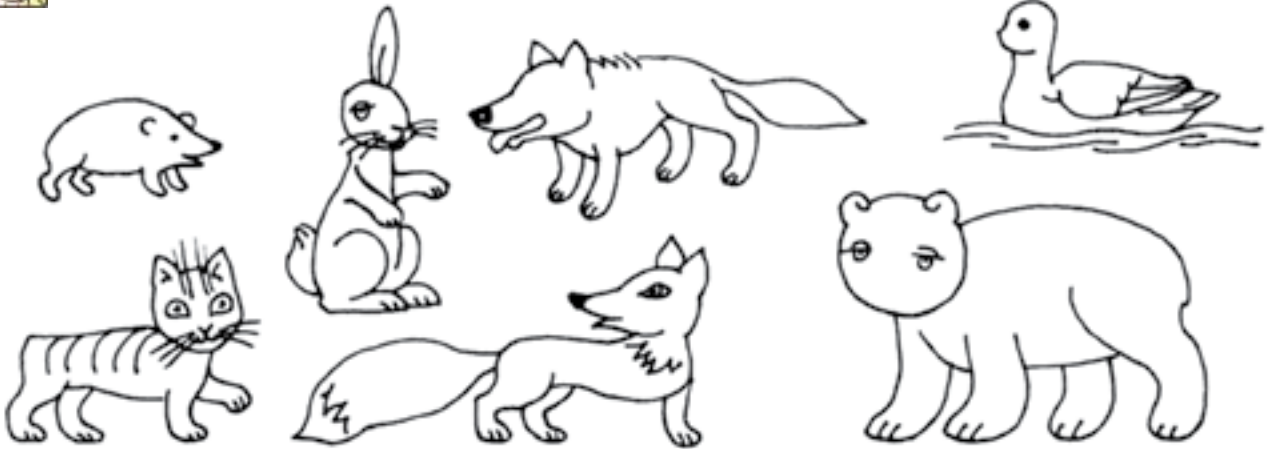

3. Baik piešti gyvūnus. Jų pavadinimuose įrašyk **a**.





4. Parvesk katinėlį pas senelę. Surink visas **a** ir **A**.

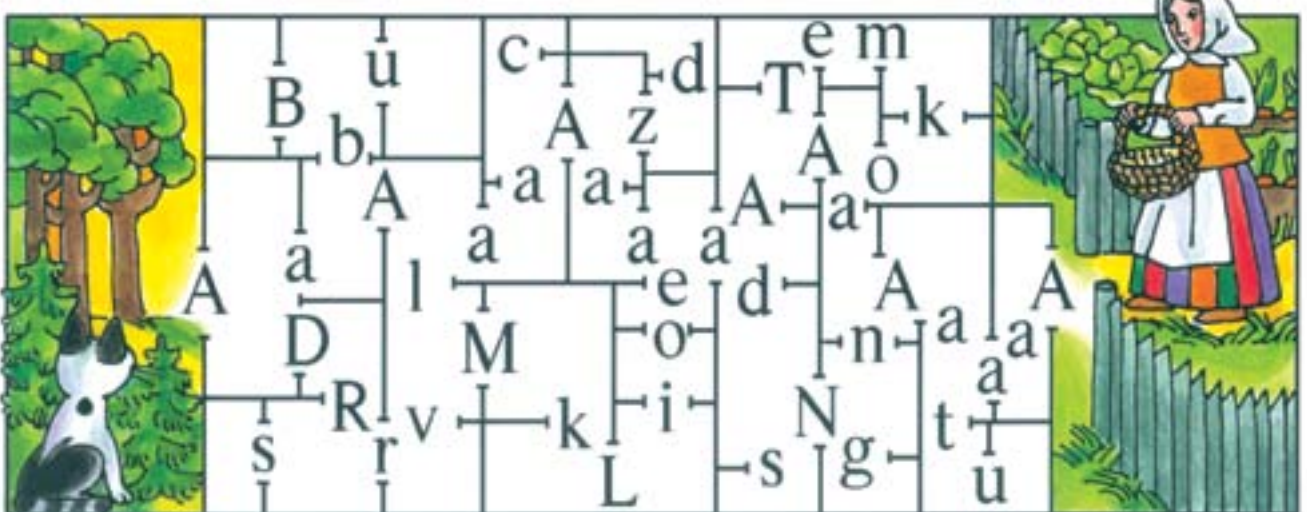

5. Parašyk.

A a



1. Pasakyk, kas nupiešta. Nuspalvink tik daržoves.

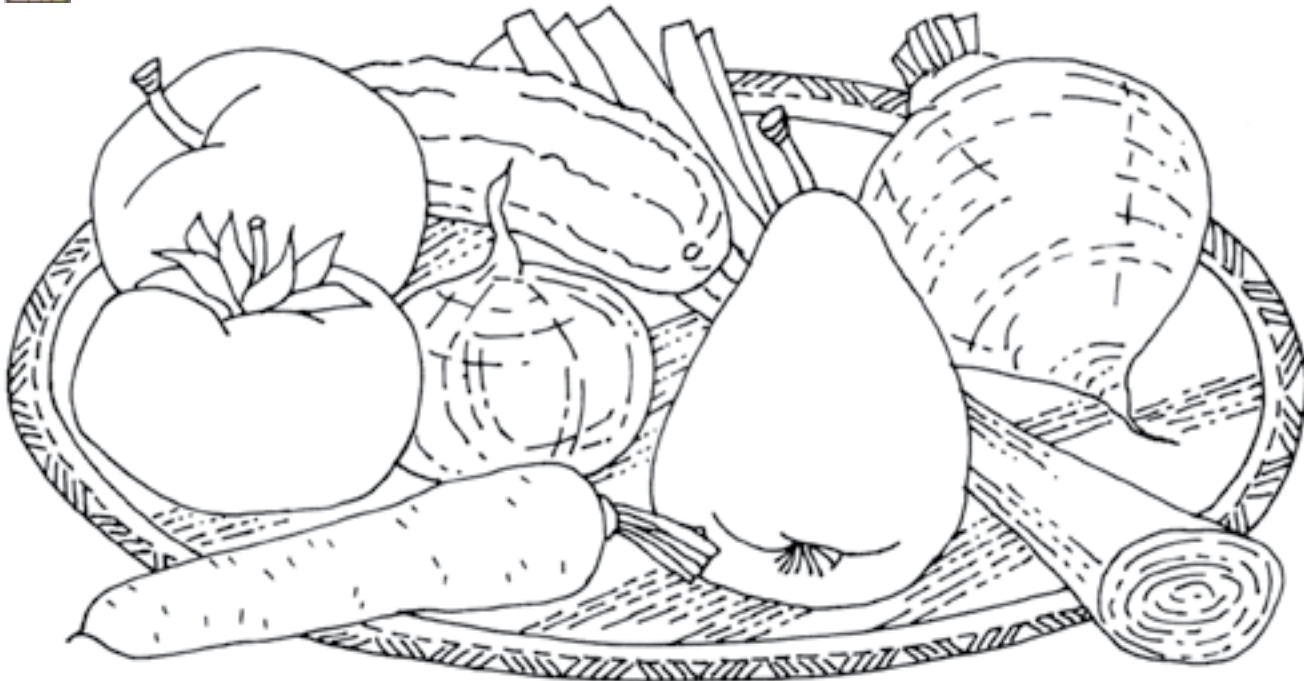

2. Baik piešti. Kurią daržovę spalvinsi žalia spalva? Kurią – raudona? Kokie bus lapeliai? Ropes nuspalvink geltonai.

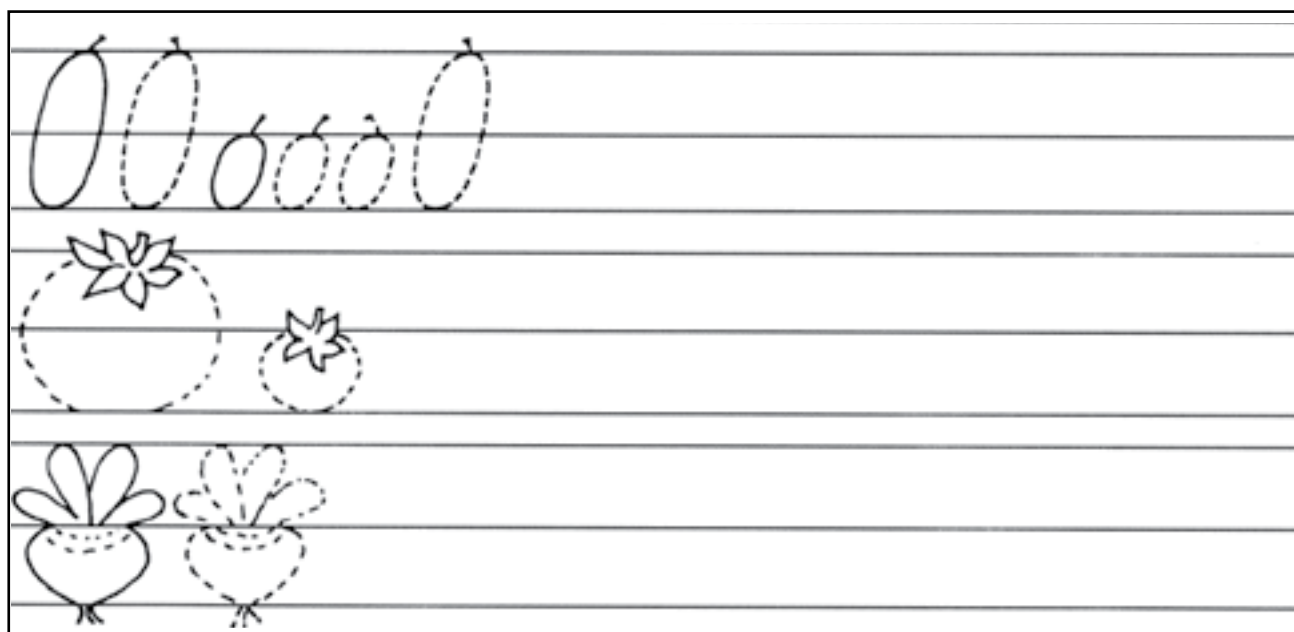

3. Tomas sėms vandenį, Ona laistys gėles, senelis rinks daržoves. Kas ką pasiims? Nubrėšk strėlytes.



o O



1. Nuspalvink piešinio dalis, ant kurių nupieštos daržovės.



2. Nuspalvink langelį, žymintį garsą o.

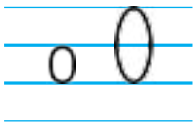

3. Parašyk raides.

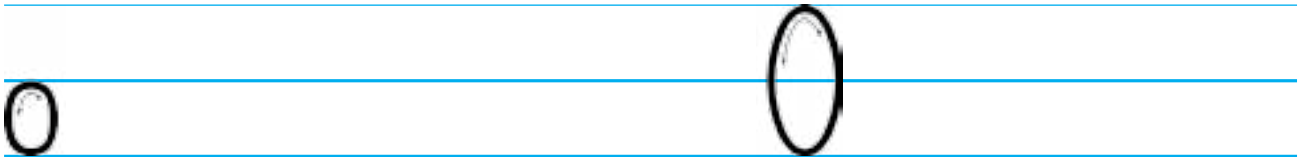

4. Pavadink daržoves. Pasakyk pavadinimus skiemenimis ir garsais.
Įrašyk o ir a.

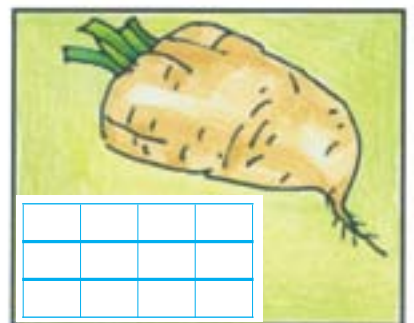
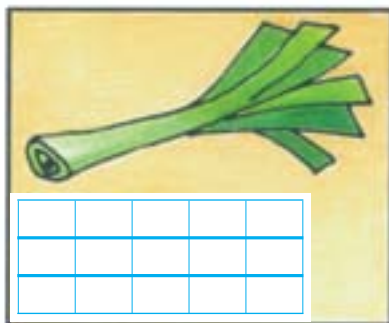
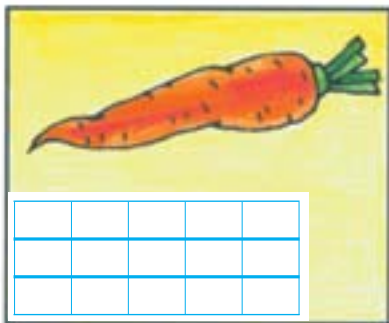

5. Rask ir nuspalvink takelį, kuriuo oželis pabėgo į mišką.

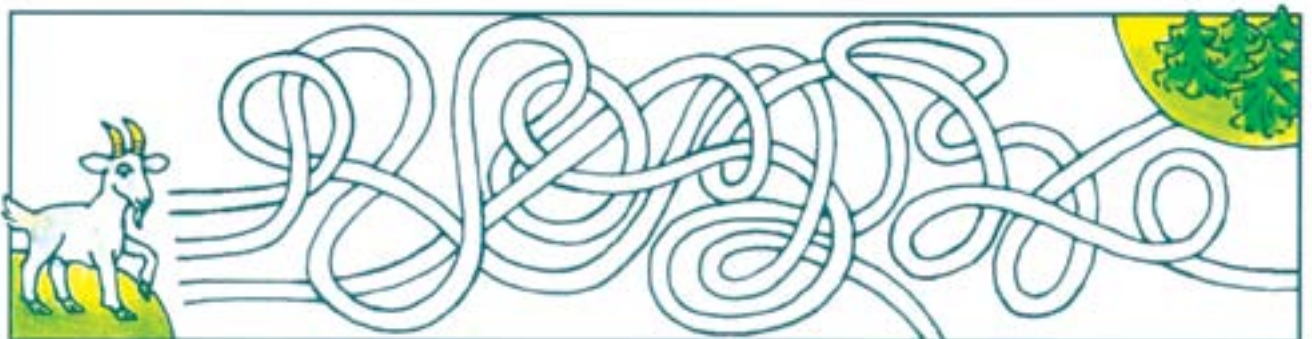



1. Nuspalvink valgomasias daržovių dalis.



2. Pasakyk vaikų vardus skiemenimis ir garsais. Įrašyk O, o ir a.

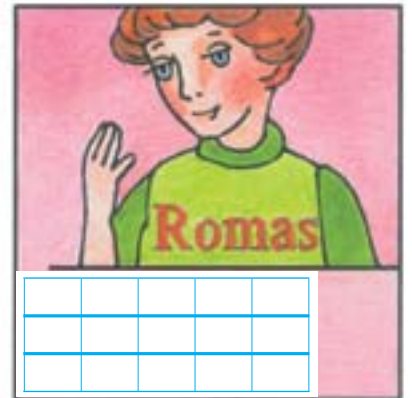
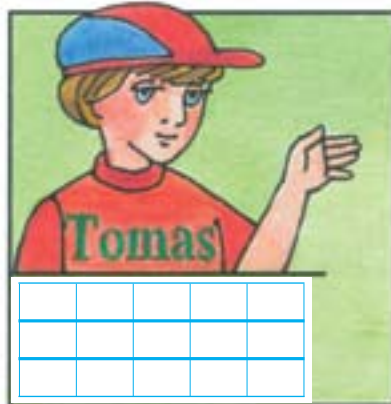
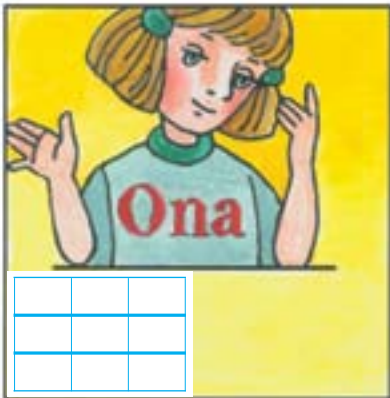

3. Pasakyk ritmiškai ir išplok dainelės žodžius.



4. Kaladėles, ant kurių yra o, nuspalvink oranžine spalva.

Vai pa ro dyk,

o že li,

Kaip bo bu tės

šo ka.



5. Parašyk.

O o



1. Surikiuok senelio pagalbininkus eilės tvarka.



2. Nuspalvink paveikslėlį pagal pateiktą kodą: **A, a, E, e, M, m, O, o.**

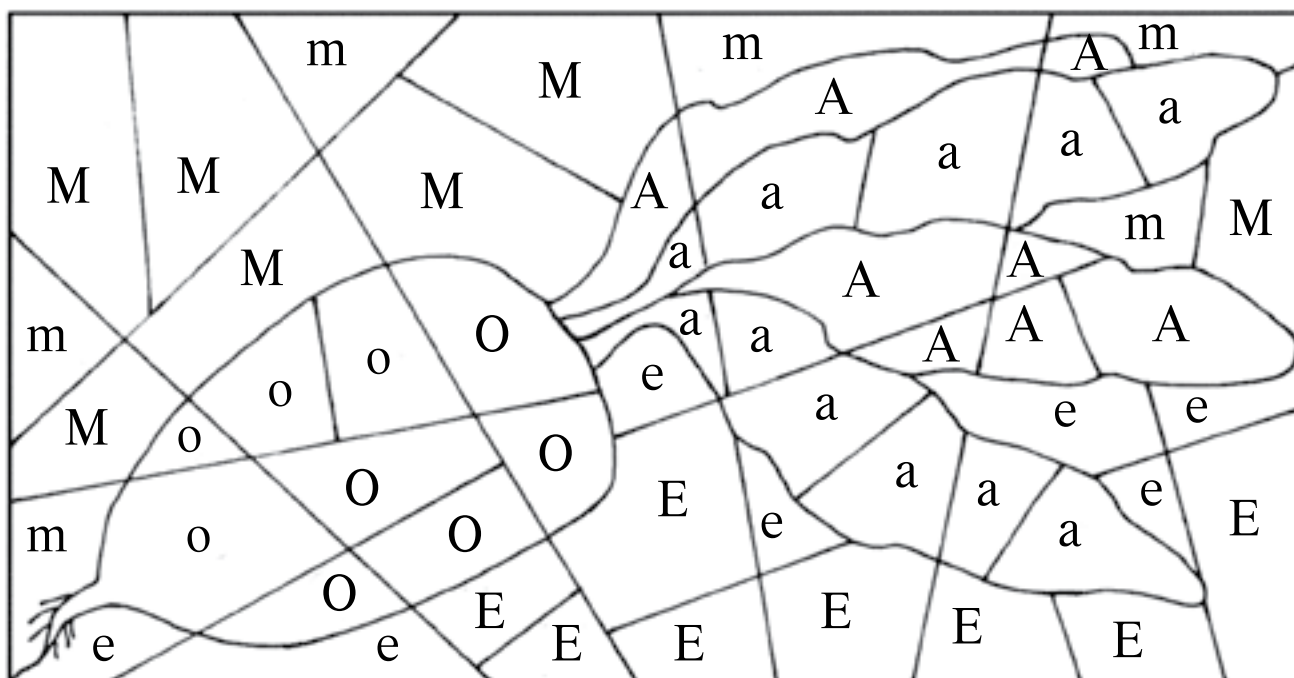

3. Kurie veideliai liūdni, o kurie linksmi? Nupiešk.

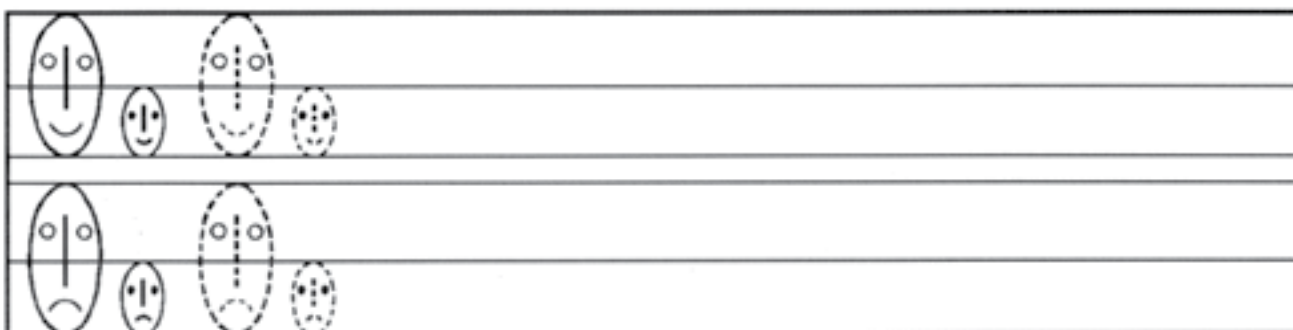



1. Kas netinka raidės o daržui? Išbrauk.



2. Parašyk.

O o A a



3. Pasakyk žodžių pavadinimus skiemenimis ir garsais. Įrašyk o ir a.

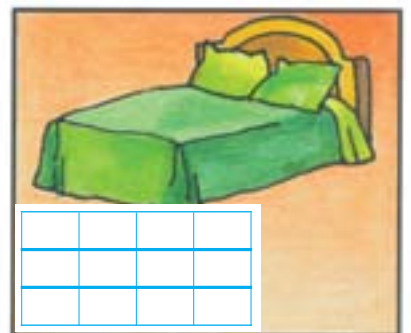
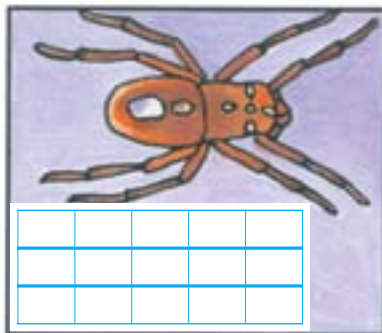
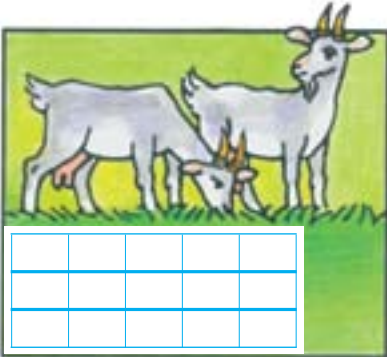

4. Ritmiškai perskaityk dainelės žodžius ir išplok ritmus.



5. Kaladėlę su raide O nuspalvink žaliai, kaladėles su raidėmis o nuspalvink geltonai, o su raide a – mėlynai.

O	pa	o	pa	o	pa	pa,
Bu	vo	žir	nis	ir	pu	pa.



6. Kas tai galėtų būti? Nupiešk.



m M



1. Nupiešk save ir mamą. Kieno kuris skėtis?



2. Nuspalvink langelius, žyminčius garsą m.

m M

--	--	--



3. Parašyk raides.

m M

m M



4. Pasakyk paveikslėlių pavadinimus skiemenimis ir garsais. Įrašyk m.

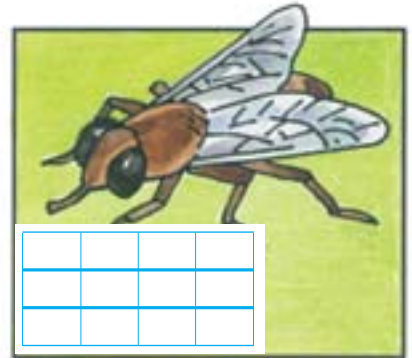
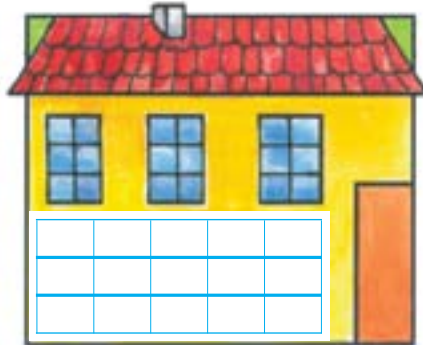
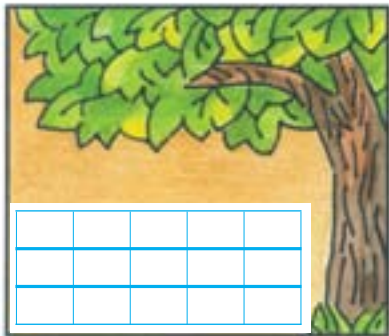

5. Išbrauk piešinius, kurie netinka raidėms m ir M.





1. Nuspalvink **a** geltonai, **m** mėlynai. Ką tau primena mėnulis?

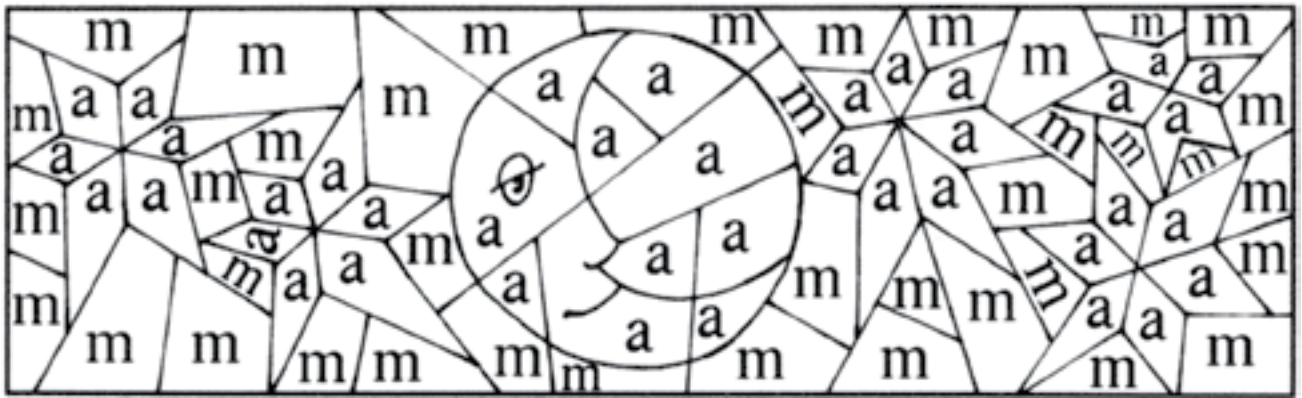

2. Perskaityk ir parašyk raides, skiemenis ir žodį.

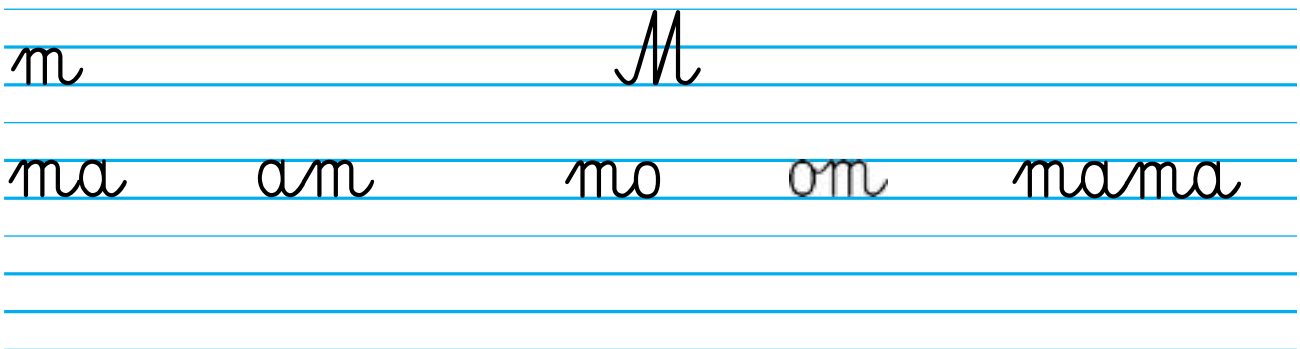

3. Ritmiškai pasakyk lopšinės žodžius.



4. **A** paryškink geltonai, **a** – žaliai, **m** – mėlynai.

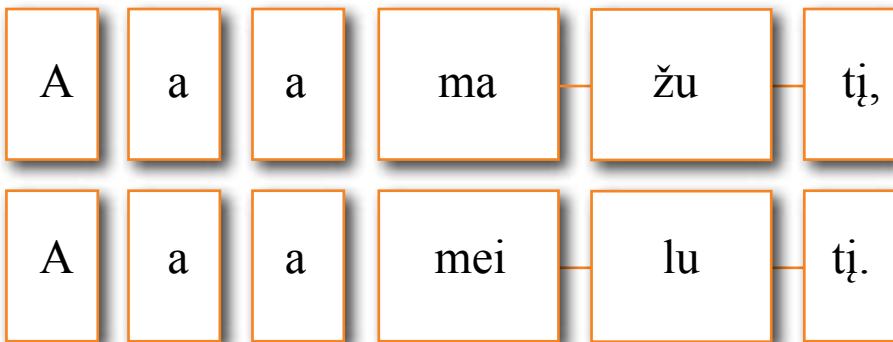

5. Į kurią lovytę kuri lėlė guls?





6. Rask ir nuspalvink siūlą, kuriuo siuva mama.

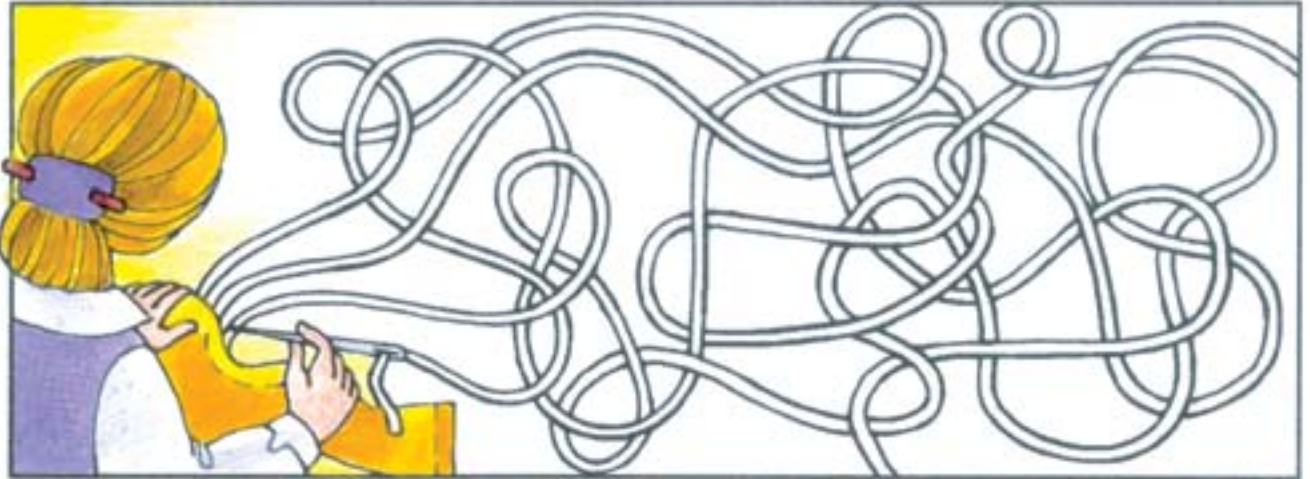

7. Pasakyk vaikų vardus skiemenimis ir garsais. Įrašyk **M**, **m**, **A** ir **a**.

Matas

Alma

Tomas

Milda



8. Nuspalvink pagal pavyzdį. Perskaityk ir kelis kartus parašyk žodį.

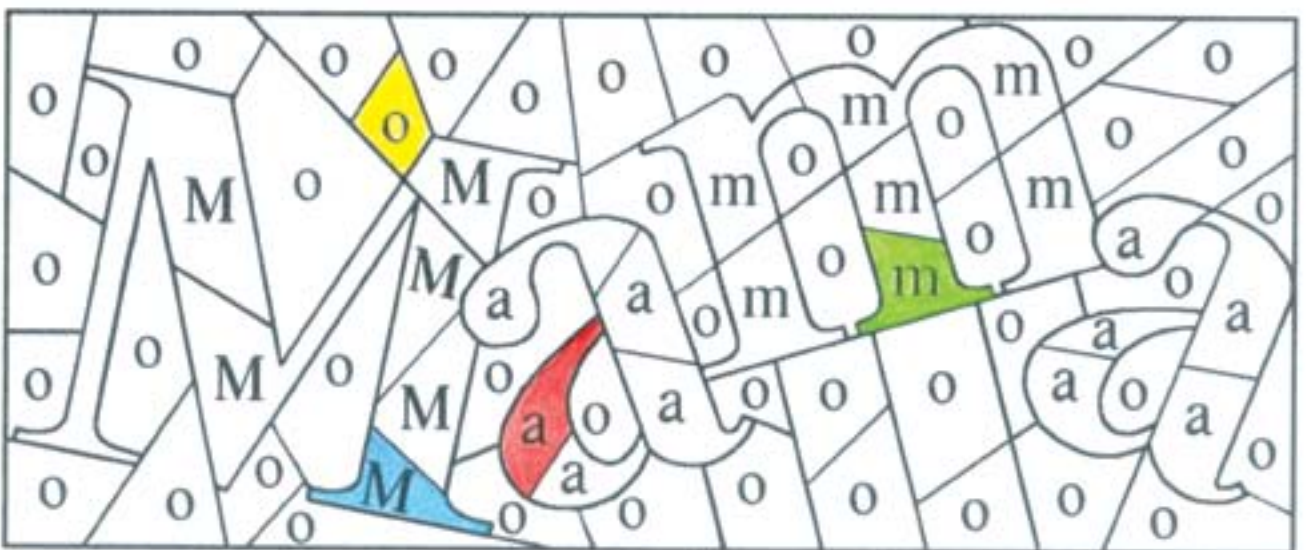

ė Ę



1. Nuspalvink taškeliais pažymėtas piešinio dalis.



2. Pasakyk gyvūnėlio pavadinimą. Nuspalvink langelį, kuris žymi garsą ė. Užaugink ėriukams vilneles.

ė Ę



--	--	--	--	--	--	--	--



3. Nupiešk vaikų tempiamas spyruokles. Kurie vaikai stipresni?

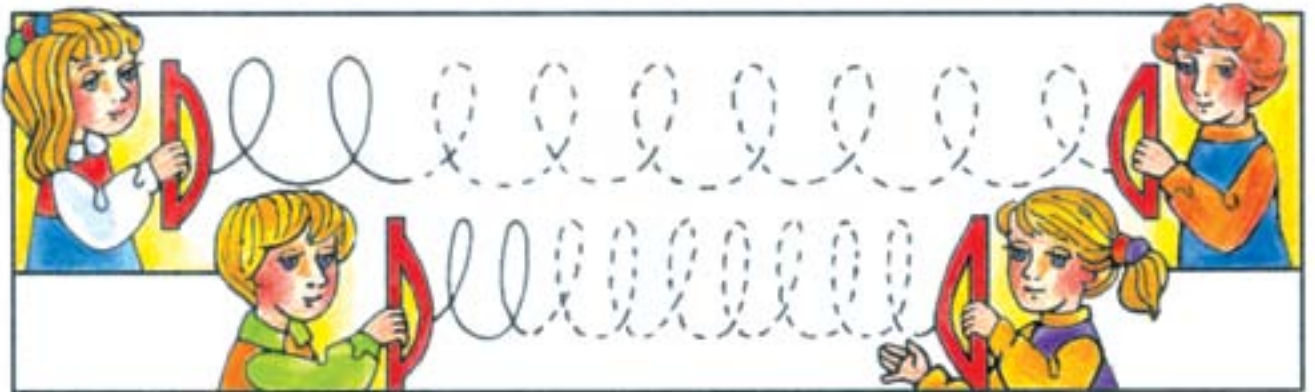

4. Parašyk raides.

ė Ę

ė Ę



5. Pasakyk paveikslėlių pavadinimus skiemenimis ir garsais. Įrašyk ė.

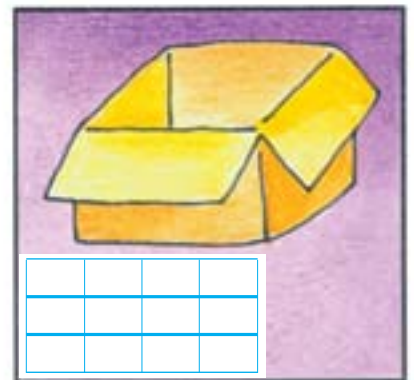
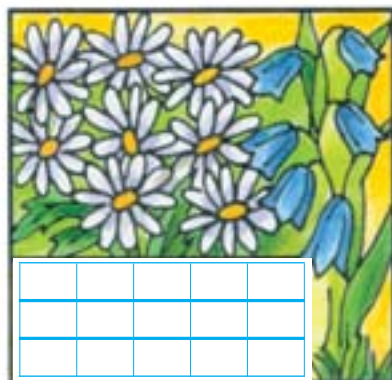
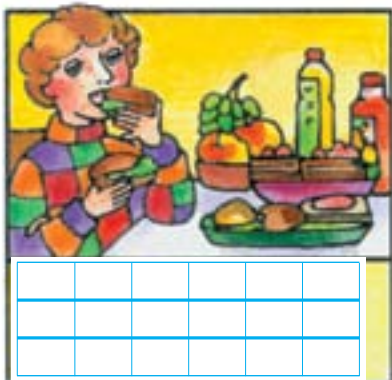



1. Nupiešk savo mamytės portretą. Širdelėje nupiešk tai, kas galėtų pradžiuginti tavo mamytę.

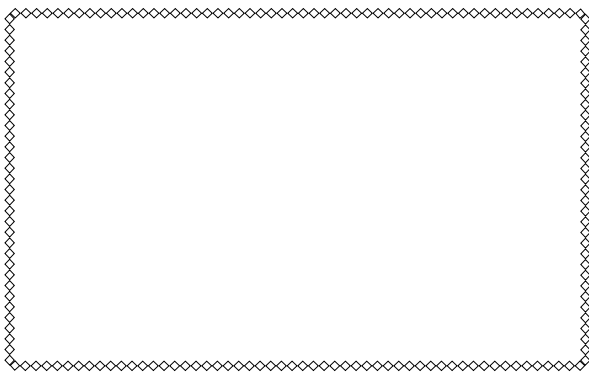

2. Padėk mamytei papuošti tortą.

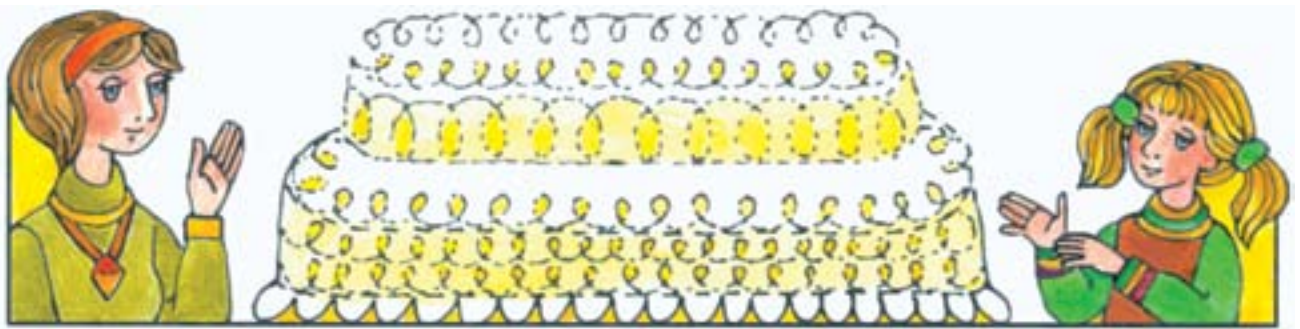

3. Perskaityk ir parašyk raides, skiemenis ir žodžius.

ė ė

em me emė

Em Me Emė



4. Nuspalvink pagal pavyzdį.



5. Perskaityk ir parašyk žodį mažosiomis raidėmis.

a	ė	a	a	a	a	a	a	a	a	a	ė	a
a	a	a	a	a	a	a	a	a	a	a	a	a
ė	ė	ė	a	m	a	a	a	m	a	ė	ė	ė
ė	a	a	a	m	m	a	m	m	a	ė	a	a
ė	ė	a	a	m	a	m	a	m	a	ė	ė	a
ė	a	a	a	m	a	a	a	m	a	ė	a	a
ė	ė	ė	a	m	a	a	a	m	a	ė	ė	ė

t T



1. Nuspalvink langelius, žyminčius garsą t.

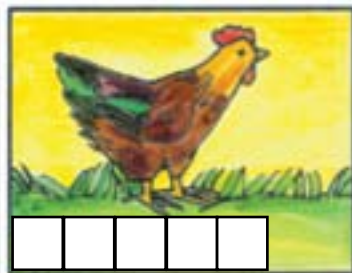
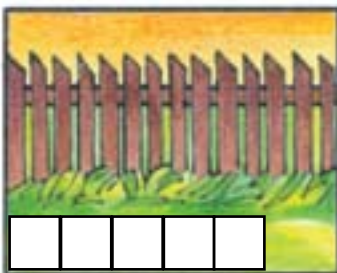

t T



2. Pabaik ir nuspalvink piešinį.

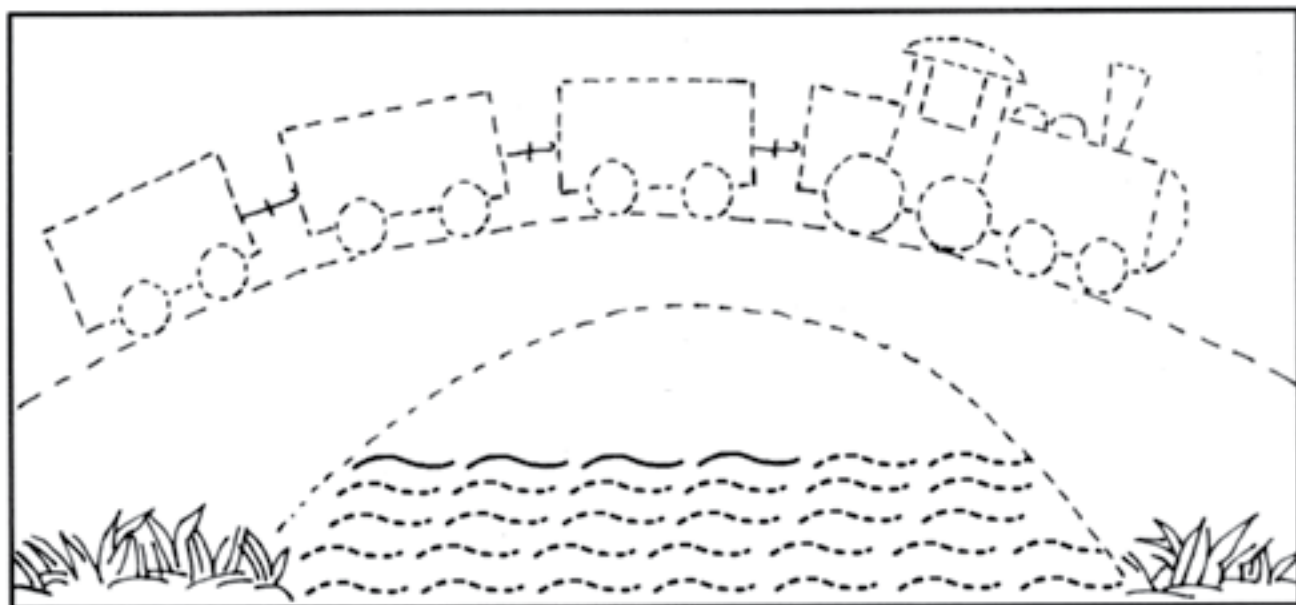

3. Parašyk raides.

t

T

t

T



4. Pasakyk paveikslėlių pavadinimus skiemenimis ir garsais. Įrašyk t.

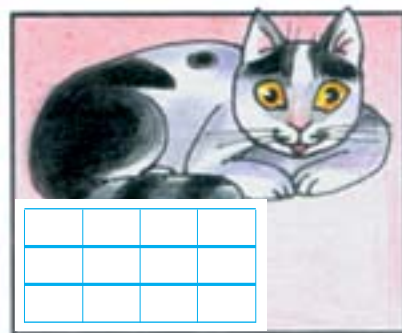
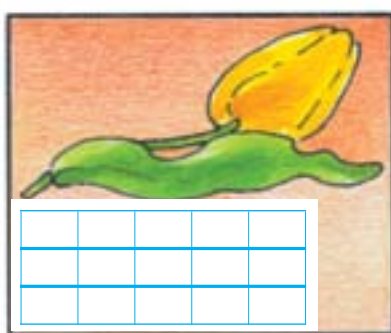
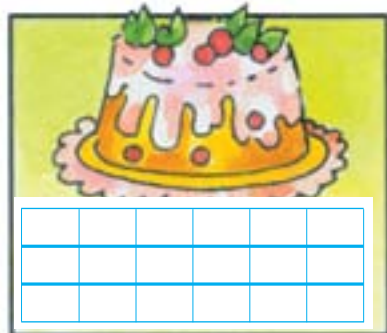



1. Kuriuo keliu tėtė nuvažiuos į pievą? Nuspalvink.

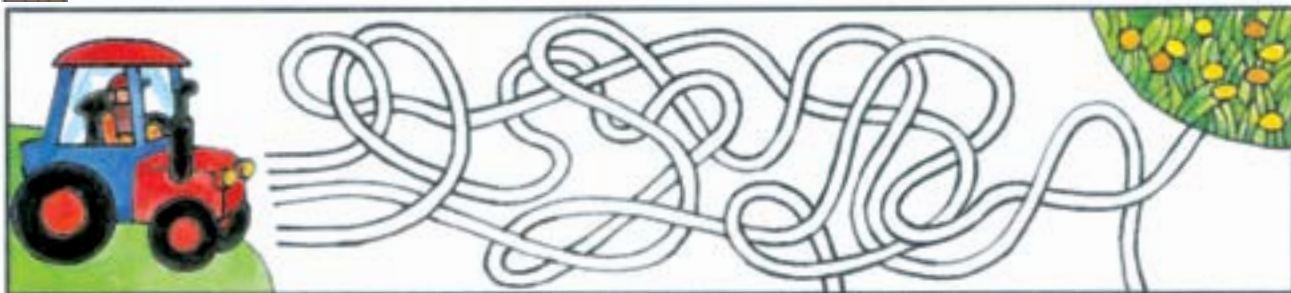

2. Perskaityk ir parašyk raides, skiemenis ir žodžius.

t T

ta to tē To Ta Tė Matė

tėtė Tėtė



3. Nuspalvink didžiųjų ir mažųjų raidžių poras ta pačia spalva.



4. Kur matai raides T ir t? Paryškink tas piešinio dalis mėlynai.





1. Nupiešk dirbančius mamą ir tėtį.



2. Po paveikslėlių pasistenk kuo daugiau parašyti žodžius **mama** ir **tėtė**.



3. Kokių profesijų žmones matai paveikslėliuose? Kokie daiktai jiems reikalingi darbe? Sujunk žmones su atitinkamais daiktais strėlytėmis.





4. Sudaryk ir parašyk žodžius.

ma	→	to
	→	tė

mė	→	ta
	→	tos



5. Pritaikyk paveikslėliams pavadinimus ir nurašyk juos.

Tomo tėtė.

Tomo mama.







6. Išplok ritmus.



7. Nuspalvink: a o M t è .

Ma	no	tė	ve	lis
Bu	vo	kal	ve	lis.

Mano tėvelis
 Buvo kalvelis.
 Tik ty ku, tak ta ku
 Buvo kalvelis.

s S



1. Nuspalvink langelius, žyminčius garsą s.

s S

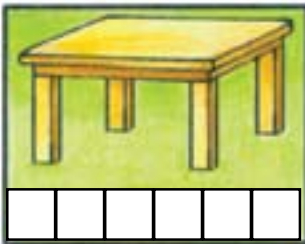

2. Papuošk servetėles.

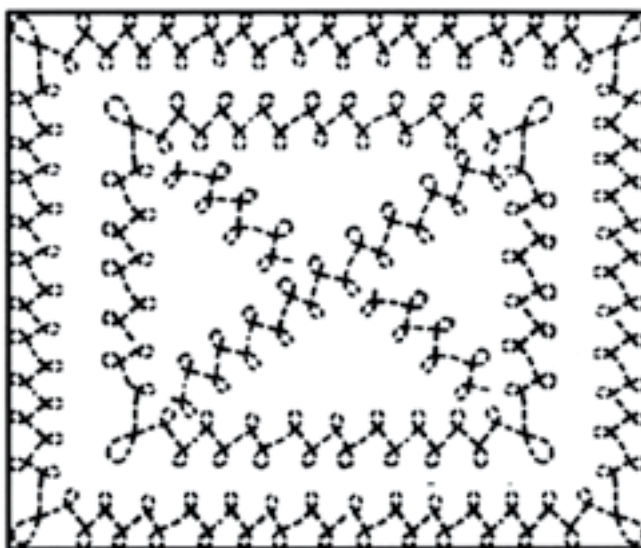
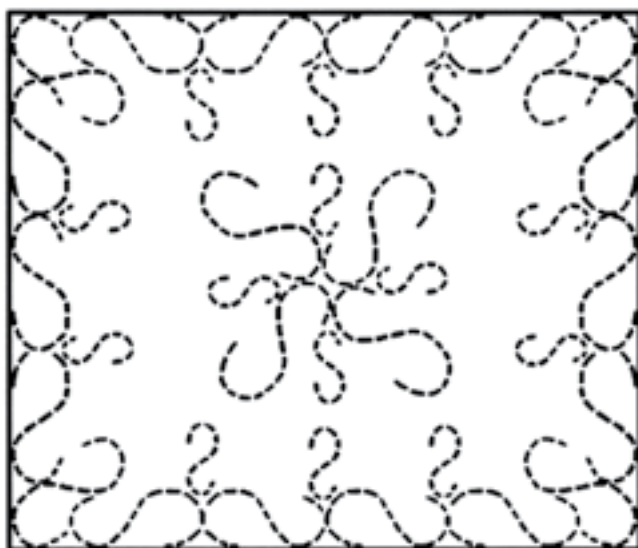

3. Parašyk raides.

s

S

s

S



4. Ko vaikai prisiskynė sode? Nuspalvink.

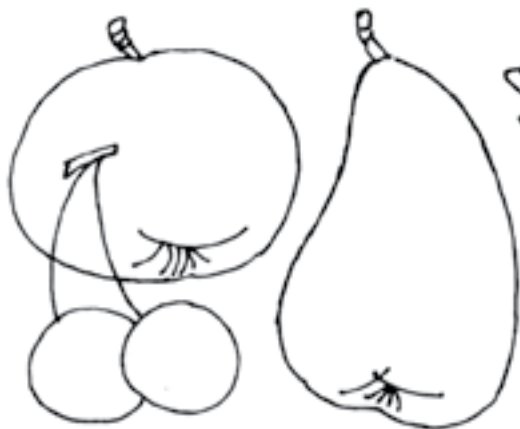



1. Įvardink vaisius. Nuspalvink vaisius, kurie auga mūsų soduose.

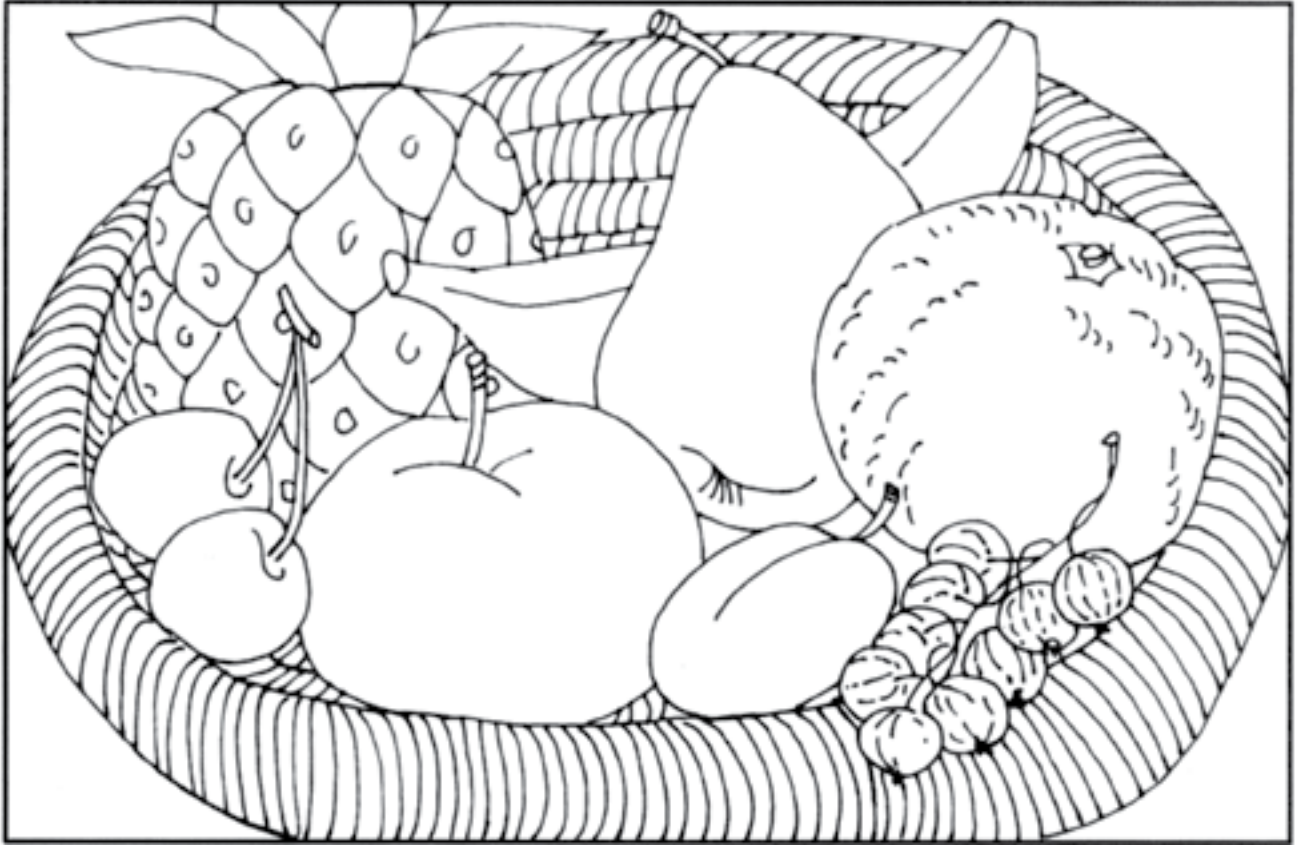

2. Parašyk raides, skiemenis ir žodžius.

s S

sa so se as os Se Sa So

sės Stos



3. Spalvotu pieštuku apibrėžk vaisių gaminius.





1. Nuspalvink raide **s** pažymėtas piešinių dalis nurodytomis spalvomis.



2. Kur girdi garsą **s** – žodžio pradžioje, viduryje ar pabaigoje? Įrašyk ten raidę **s**.

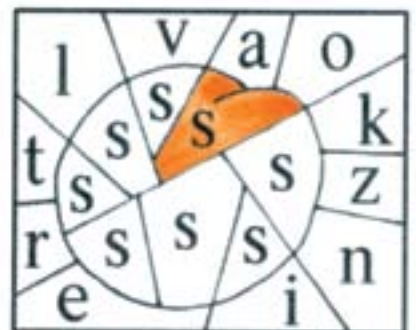
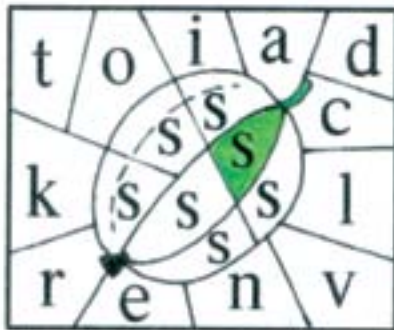
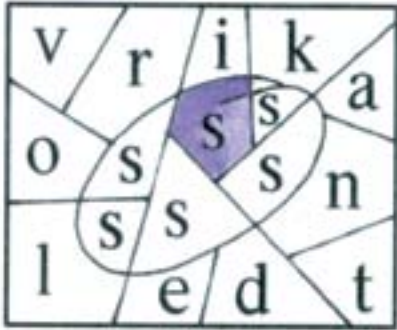



3. Sujunk tos pačios rūšies vaisius. Perskaityk ir parašyk žodžius.



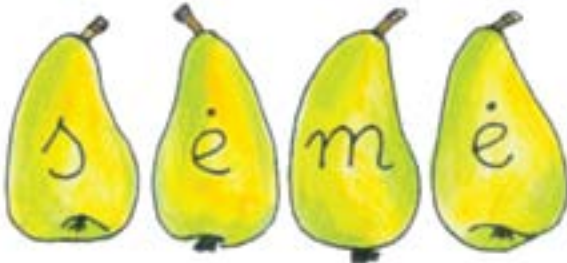





4. Iš spalvoto popieriaus išklijuok vaisiaus, kurį labiausiai mėgsti, atvaizdą.





5. Nuspalvink nurodytomis spalvomis serbentų krūmo ir obels dalis.

vaisiai

lapai

šakos

kamienas

šaknys



6. Pažymėk paveikslėlių eilę. Papasakok, ką veikia vaikai.

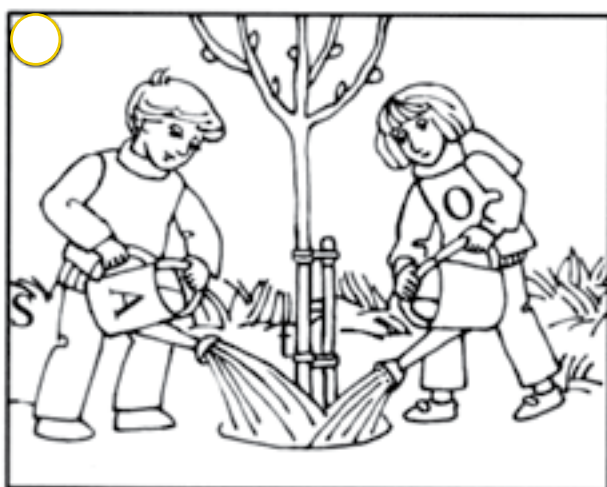
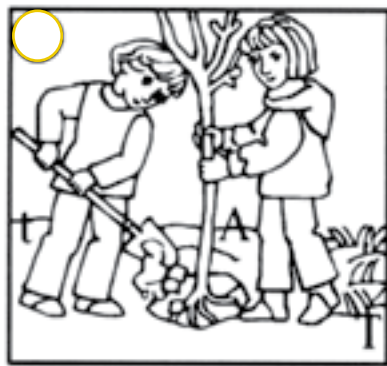

7. Rask ir nuspalvink piešiniuose pasislėpusias raides. Parašyk jas.



1. Sudėk vaisius ir daržoves į atitinkamas pintines.



2. Nuspalvink tuos piešinius, kurių pavadinimuose girdi garsą **s**.



3. Nurašyk sakinius. Paryškink didžiąsias raides.

Astos mama sės metas.

Tomo tėtė sėmė žuvis.



4. Ritmiškai pasakyk pasakėlės pradžia.



5. Nuspalvink kaladėles su raide **s**.

Viens,

du,

trys –

tu

su

plok

Ir

gra

žiai

nu

si

šyp

sok.



1. Nupiešk savo mokytojos portretą ir nuspalvink jai skirtą rudeninę puokštę.

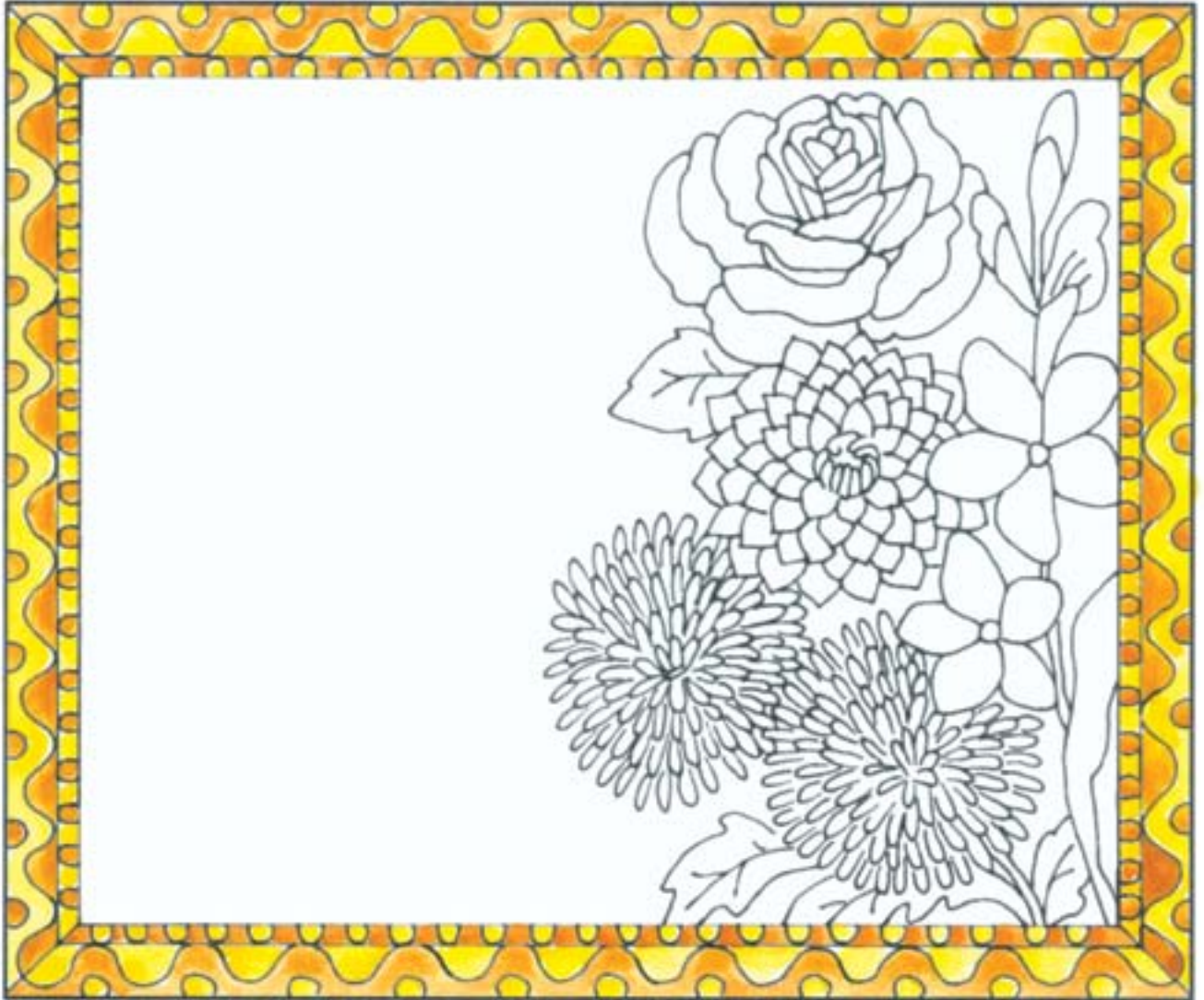

2. Surask ir parašyk, kuris vaikas kurią gėlę nupiešė.

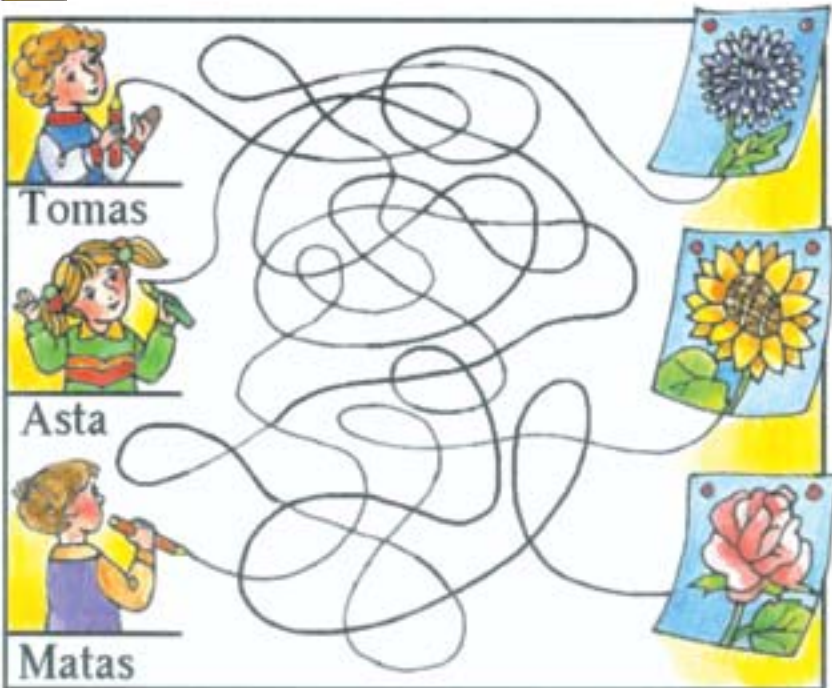



1. Kurias raides jau pažino meškiukas Rudnosiukas? Parašyk pirmoje eilutėje didžiąsias, o antroje mažąsias raides.

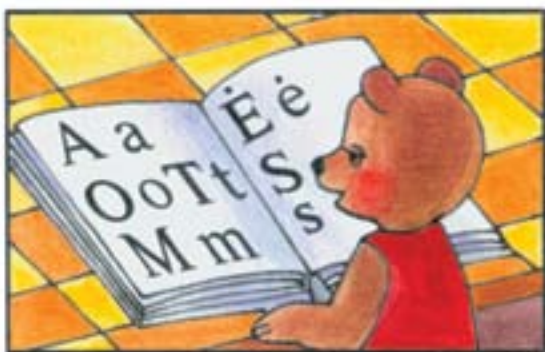



2. Kuriam meškiukui kuris medus priklauso?

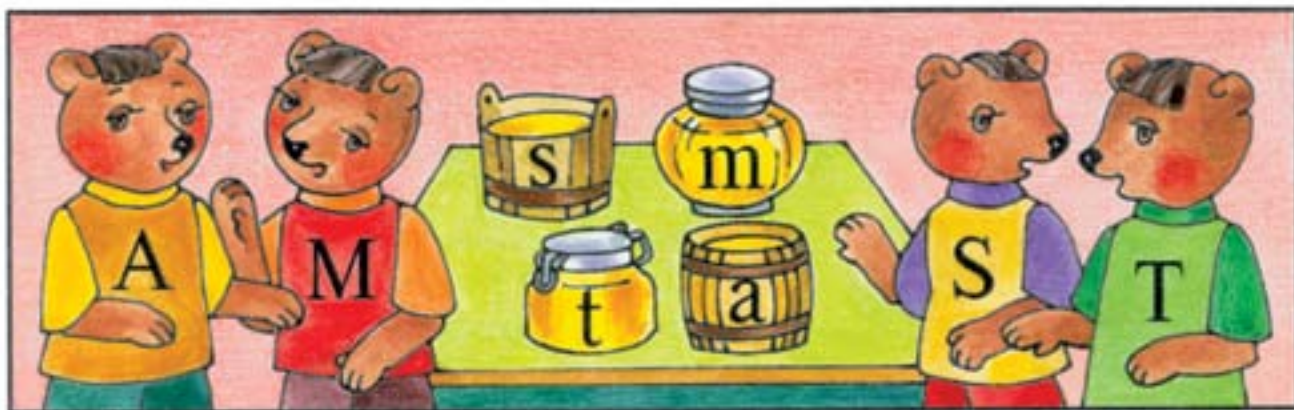

3. Perskaityk, kokius žodžius moka parašyti Rudnosiukas. Pamėgink parašyti ir tu.

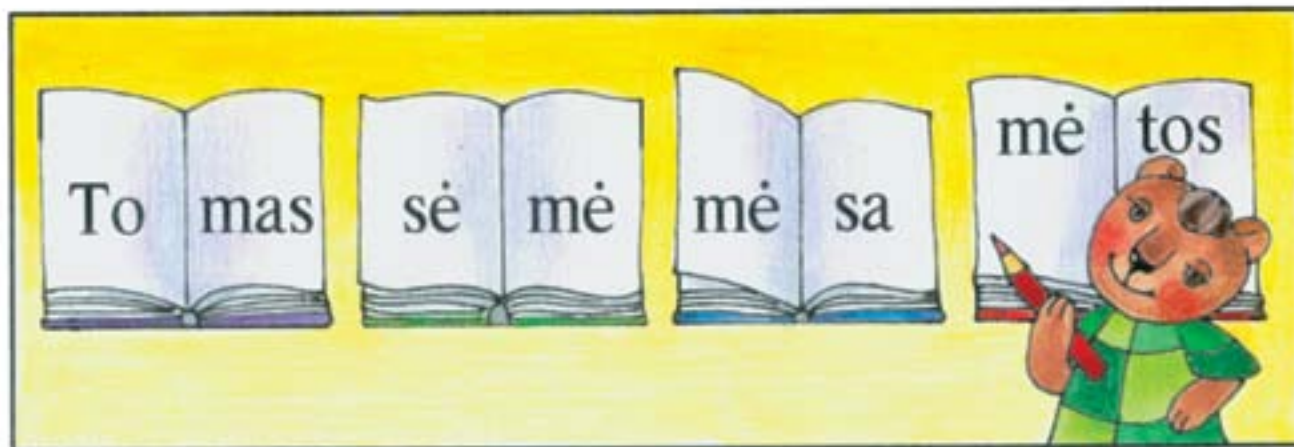



4. Raidės pasiklydo. Rask jų vietą žodyje.

m Ė ė
□ □ □

ė ė m t
□ □ □ □

a t M a s
□ □ □ □ □

ė t m a
□ □ □ □

e E



1. Langelius, kurie žymi garsą e, nuspalvink raudonai, o langelius, žyminčius garsą è – žaliai.

e È

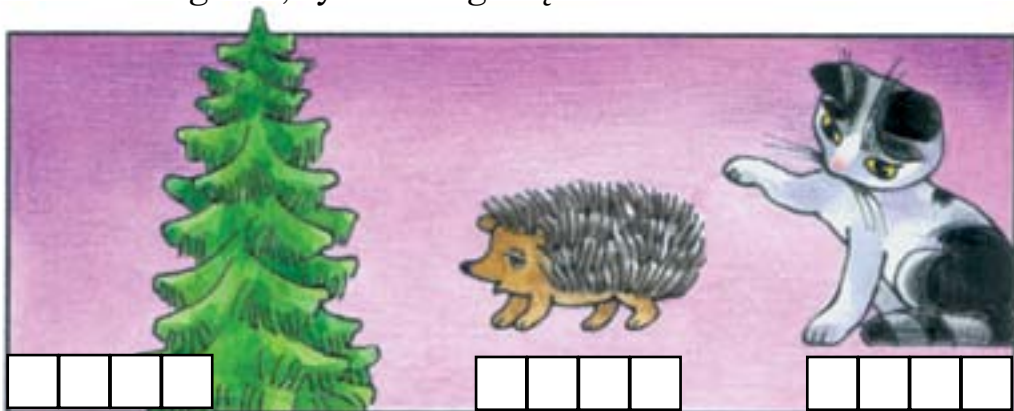

2. Parašyk raides.

e È

e È



3. Ką vaikai matė miške? Pasakyk pavadinimus skiemenimis ir garsais. Įrašyk e ir è.

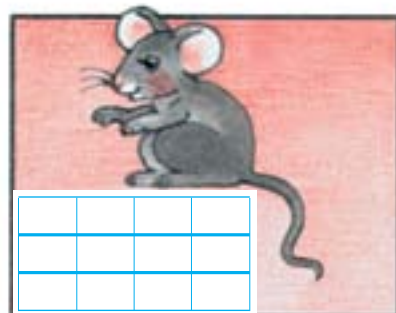
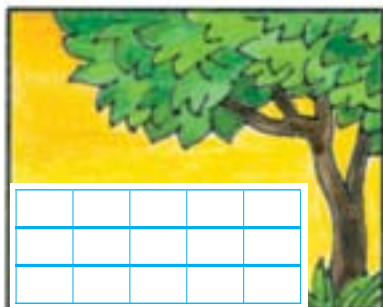

4. Išdykaudami ežiukai susikeitė kepurėlėmis. Kuri kepurėlė kuriam ežiukui priklauso? Pažymėk rodyklėmis.





1. Kurie gyvūnai pasiklydo? Išbrauk juos.



2. Pabrauk **E** ir **e** raudonai, o **Ė** ir **ė** – mėlynai.

Ėdžios šernas lapė voverė **meška**
 gegutė genys kelmas **Ežys**
 bitė pelėda Ėriukas bebras



3. Parašyk raides, skiemenis ir žodžius.

e Ė

em et es me te se Em

sese tata mes metė Sese



4. Vaikus parvesk namo, o žvėrelius nuvesk į mišką. Takelius nuspalvink nurodytomis spalvomis.

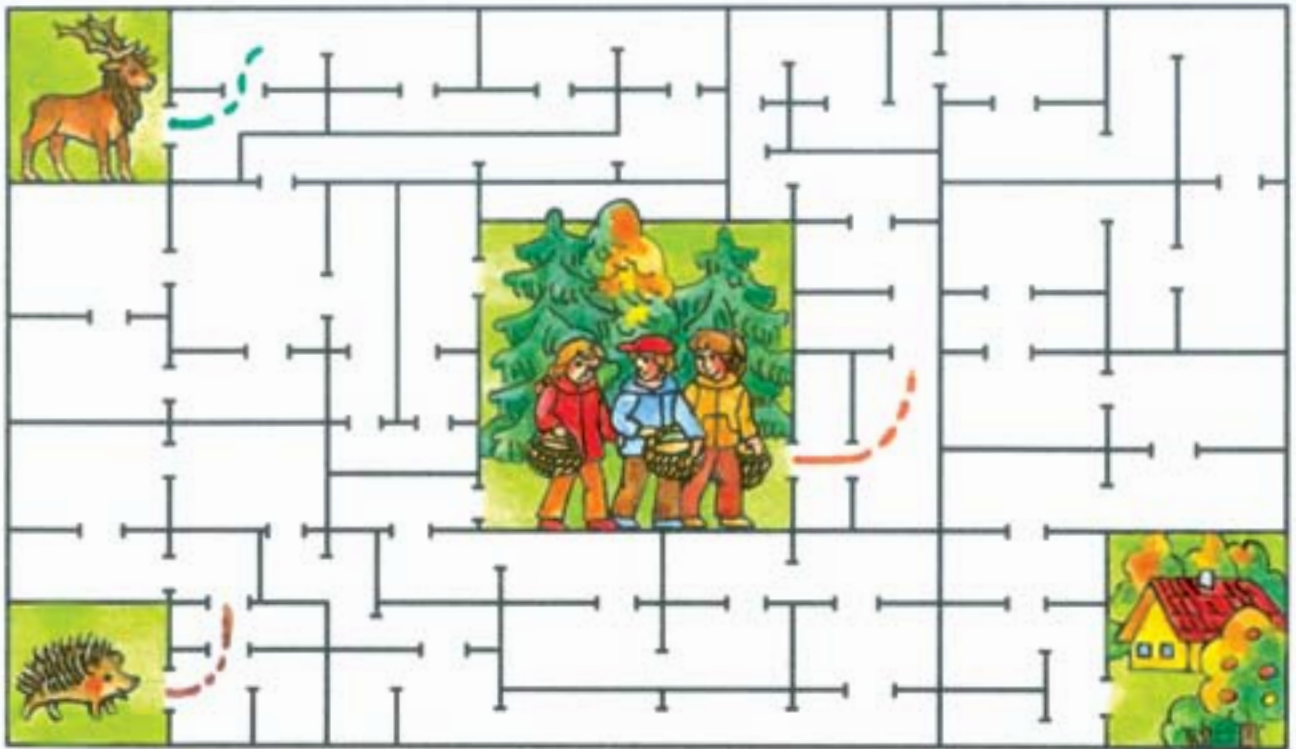

5. Kieno kuris ežiukas? Nupiešk strėlytes ir parašyk.

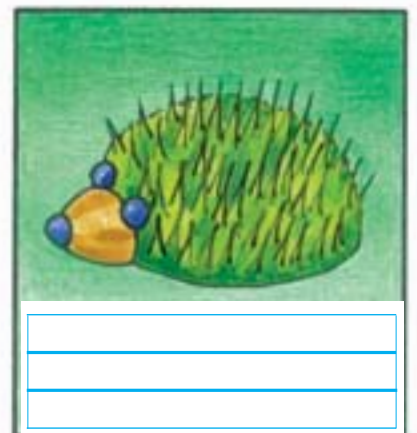

6. Kuris ežiukas tau labiausiai patinka? Padaryk tokį patį.



1. Kurie iš šių augalų medžiai, o kurie krūmai? Krūmus apibrėšk žalia spalva.



2. Kuriems iš jų priklauso šie lapai ir vaisiai? Nurodyk strėlytėmis.

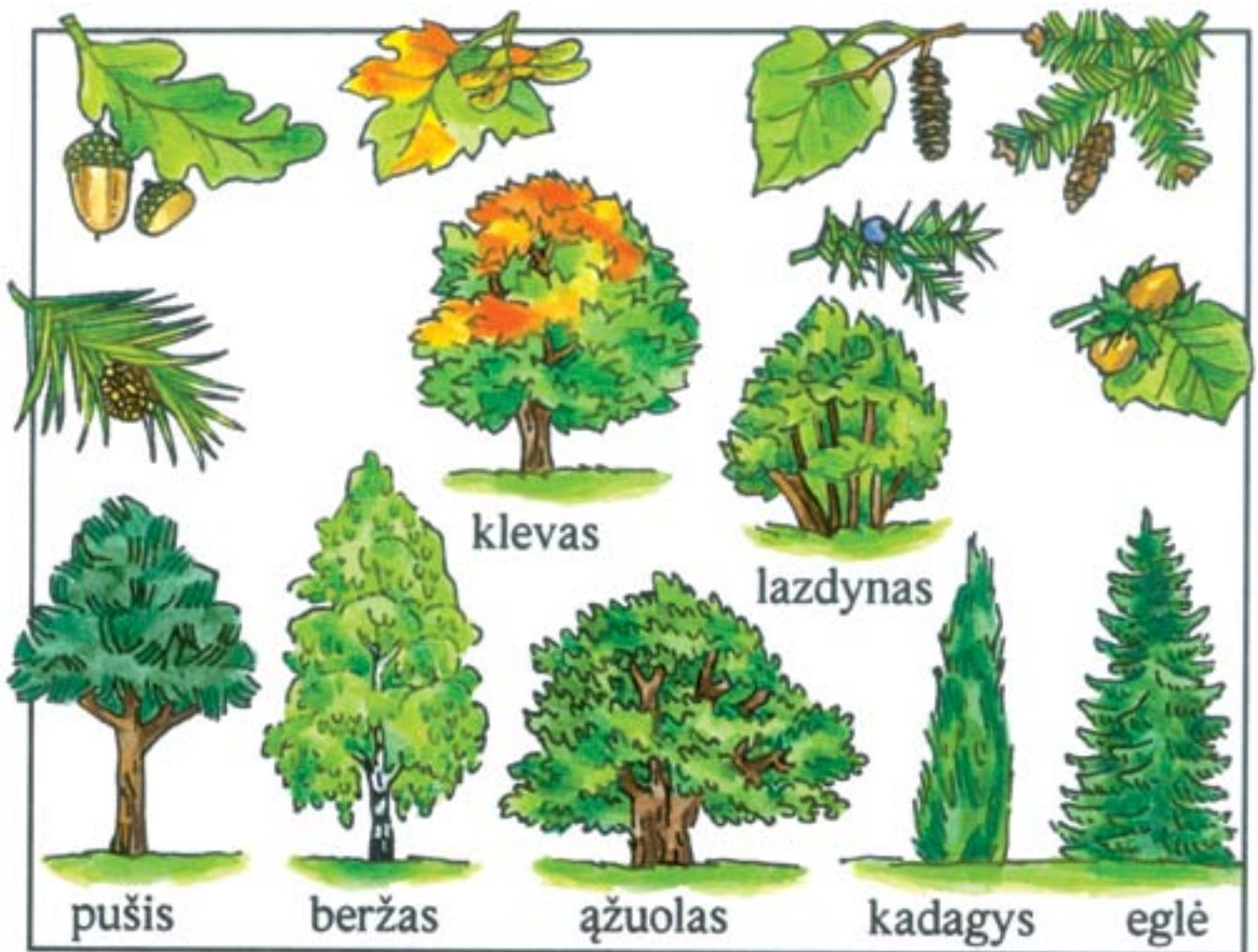

3. Nuspalvink **a** **e** **ė** **s** medžių ir krūmų pavadinimuose.



4. Nupiešk eglutes ir genius.

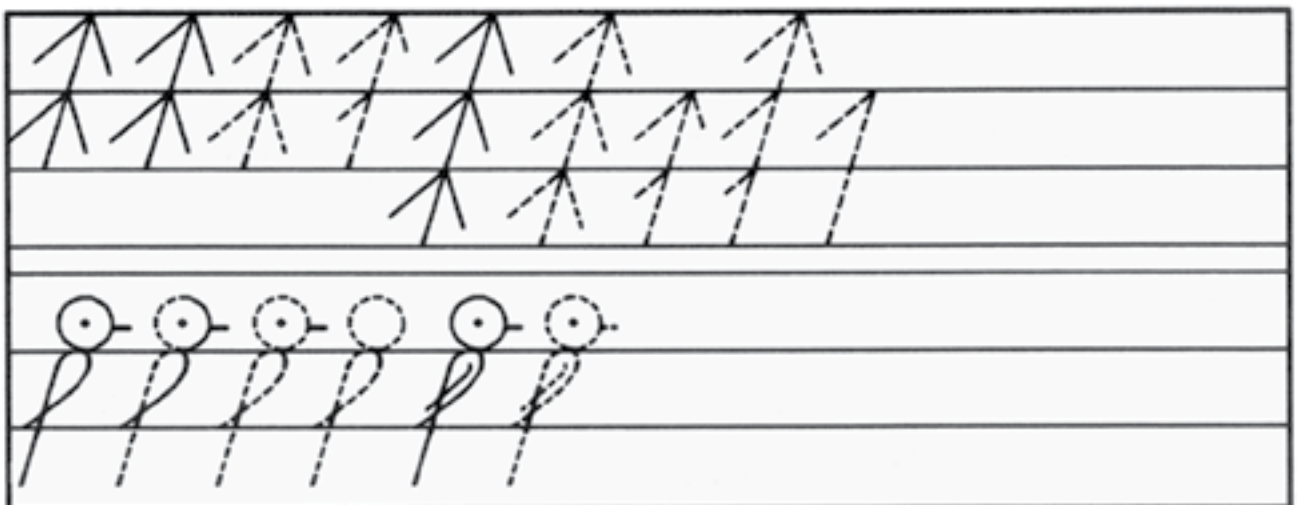



5. Pritaikyk paveikslėliams pavadinimus ir parašyk juos.

Tomo sesė Asta.

Tomo teta Stasė.







6. Papasakok, kas nutiko raidėms Ė, è.



7. Kurios raidės netinka? Išbrauk jas.



8. Kuriuose žodžiuose girdi e, o kuriuose è? Išbrauk nereikalingas raides.



e è

e è

e è

e è

e è

e è



1. Apibrėžk miško medžius – ○, krūmus – △, grybus – □, uogas – □.



2. Po lietaus pridygo grybų. Išvardink juos ir nuspalvink.

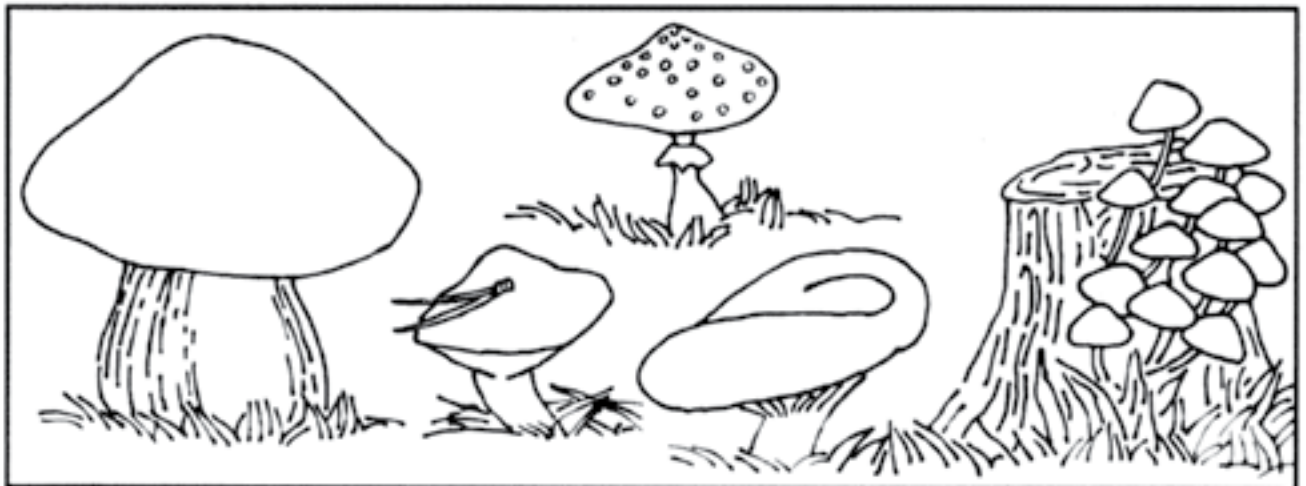

3. Nupiešk.

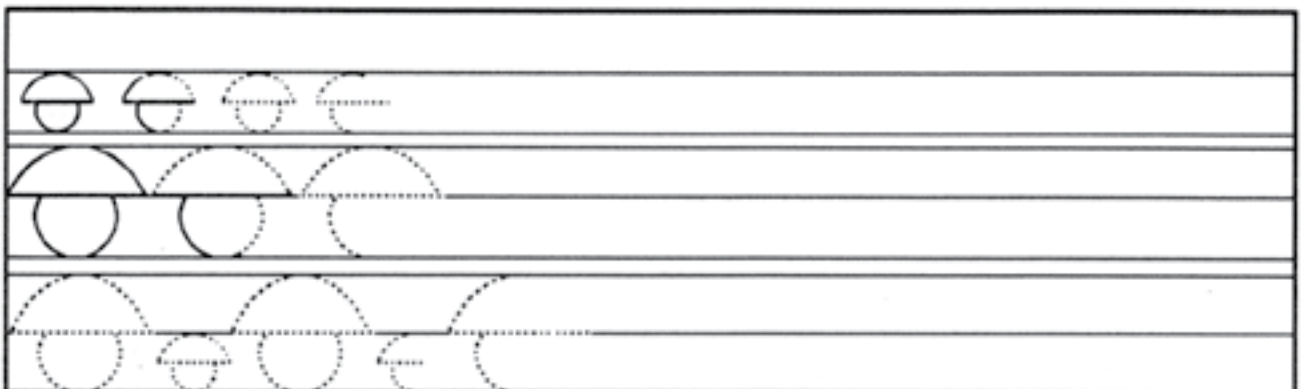



4. Suverk grybus ant siūlelių – sudaryk ir parašyk žodžius.

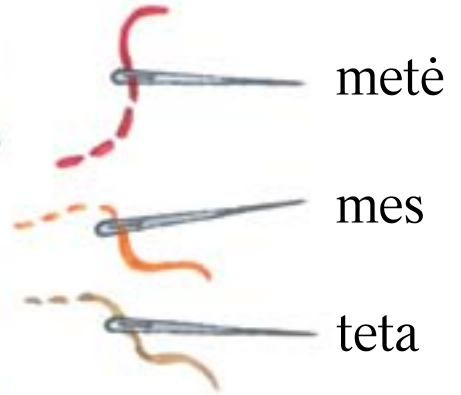

5. Nuspalvink taip, kaip pradėta. Sujunk grybo dalis su jų pavadinimais.

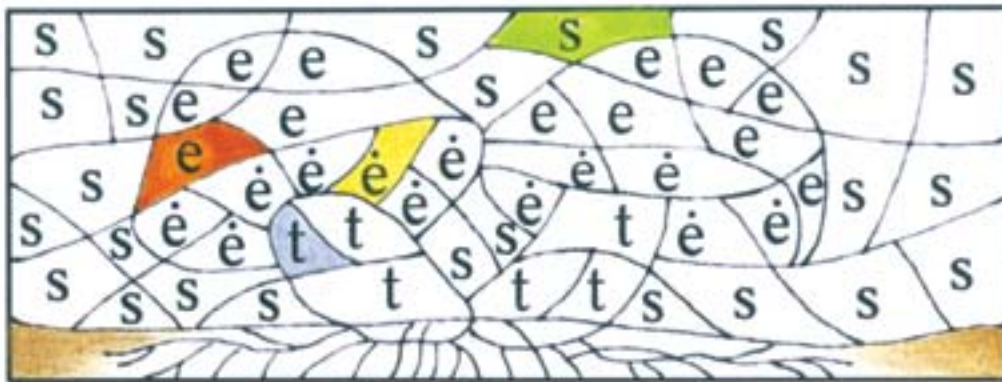

kepurė
kotas
grybiena



6. Kuris grybas kuo groja? Kokiai grupei priklauso šie instrumentai? Kodėl?





1. Ant kurių kapų per Vėlines uždegsi žvakutes? Nupiešk jas prie atitinkamų nuotraukų.



Artimųjų kapai



Senųjų kaimo kapinių kapai



Kareivių kapai laukuose



Savanorių kapai Seinuose



2. Prie didžiosios raidės parašyk mažąją.



3. Lapus su balsėmis nuspalvink raudonai, o su priebalsėmis – žaliai.





1. Baik piešti ir nuspalvink Vėlinių vainiką ir žvakutes. Nupiešk žvakutėms liepsneles.

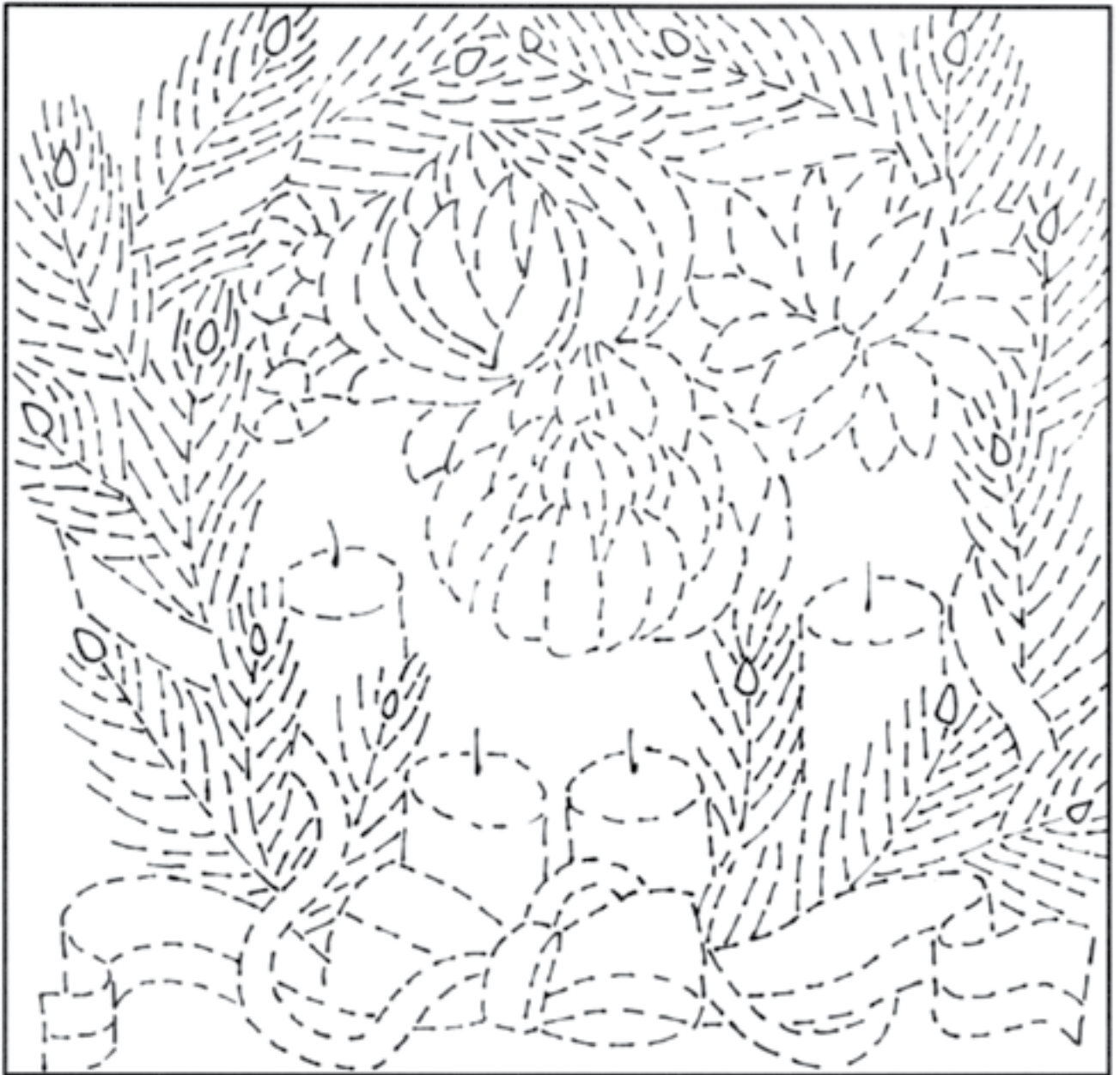

2. Sudaryk ir parašyk žodžius.

se	→	sė
Sta	→	ta

me	→	ta
te	→	ta

l L



1. Nuspalvink langelius, žyminčius garsą l.

l L

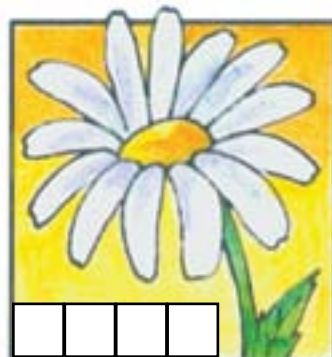
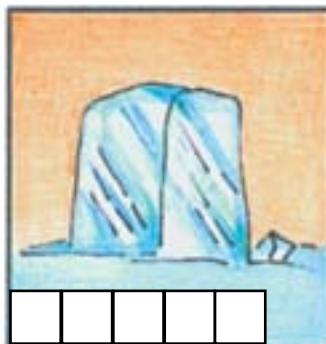
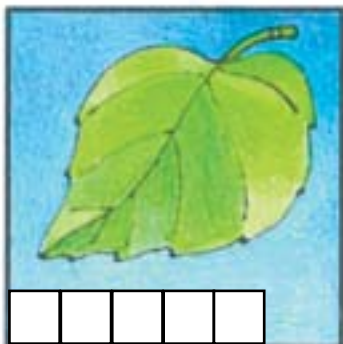

2. Ko trūksta žaisliukams? Nupiešk.



3. Parašyk raides ir skiemenis.

l L

l L

le el lo ol la le



4. Pasakyk daiktų pavadinimus skiemenimis ir garsais. Įrašyk l.

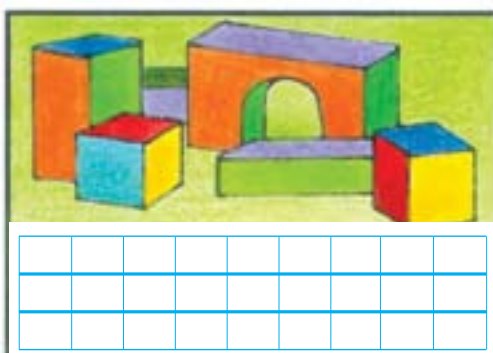
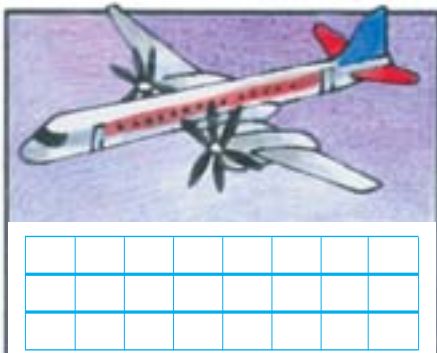
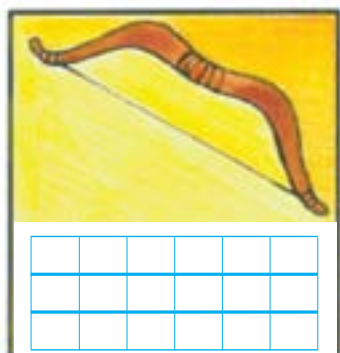



5. Pasidaryk lėlę.

Paimk: , , , , , .

Sujunk , aprišk , nupiešk .

Iškirpk . Uždėk ir užrišk .

Užrišk .  .



6. Kas netinka raidėms L ir l? Išbrauk.



L l



7. Rask ir nuspalvink dvi tokias pačias lėles.





1. Kuo negalima žaisti? Išbrauk.

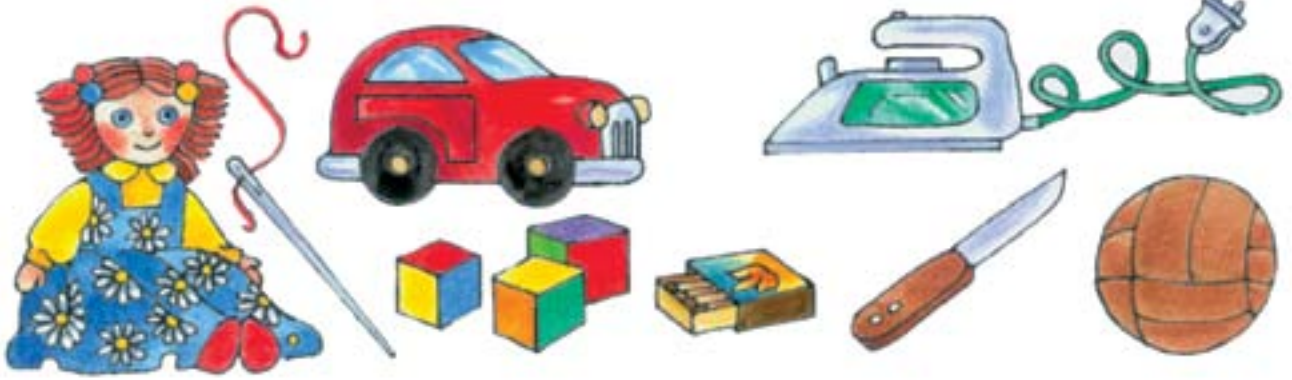

2. Rask ir pabrauk raides **l** ir **L** mėlyna spalva.

langas lova lapė kalvė klasė kelnės malūnas
kelmas kėlė lazda lėkė pelėda Linas



3. Parašyk raides, skiemenis ir žodžius.

l L
la lo lė al ol el La Lo Lė
Alė Elė Olė Molė malė



4. Perskaityk žodžius. Pasitikrink, ar moki parašyti paveikslėliams pavadinimus.





5. Išspręsk kryžiažodį.



6. Nupiešk kryžiažodžio sprendimą.

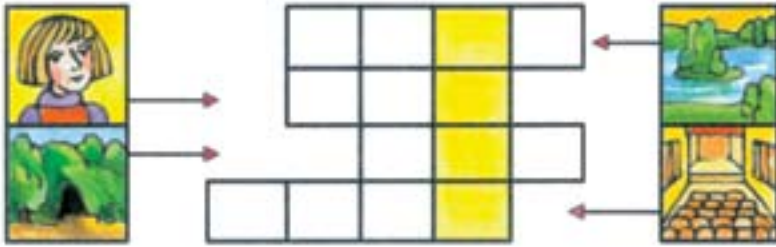

7. Nuvesk mergaites pas jų lėles.



8. Papildyk sakinius.

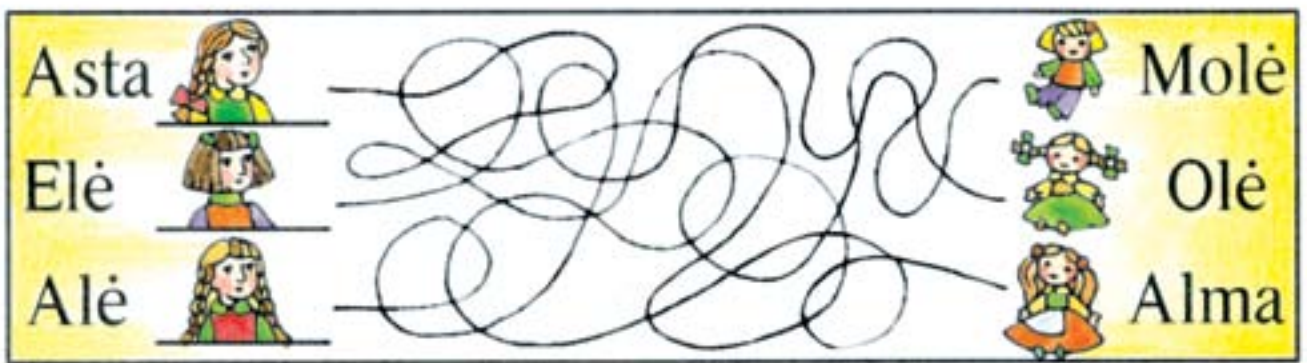

Astos lėlė

Elės lėlė

Alės lėlė



9. Perskaityk ir pamėgink parašyti žodžius.

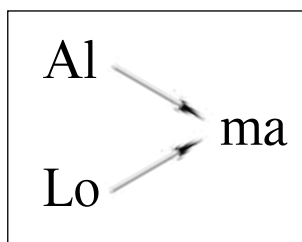
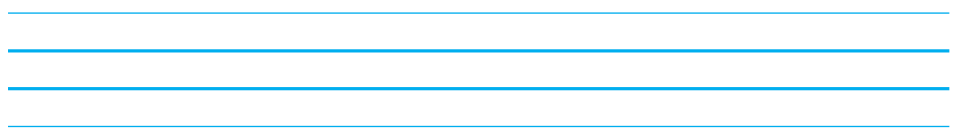
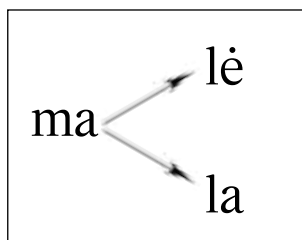

k K



1. Nuspalvink langelius, žyminčius garsą k.

k K

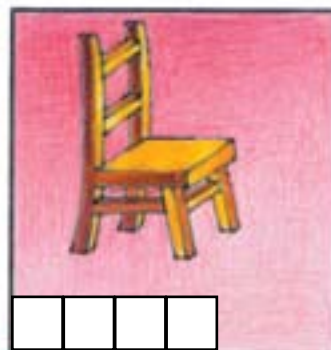
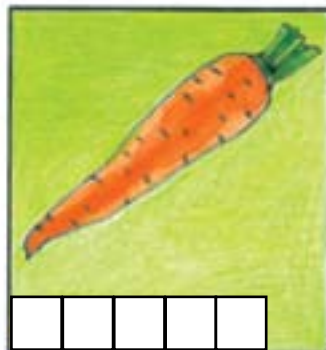
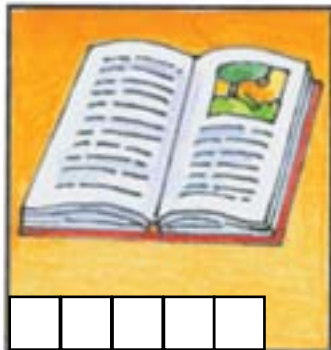

2. Įmesk kamuolį į krepšį – bėk keliu, kuris pažymėtas raidėmis k ir K.

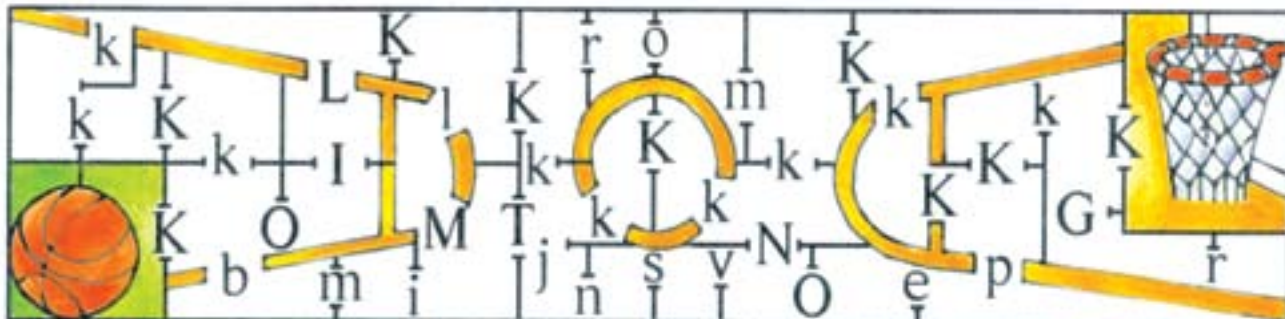

3. Parašyk raides ir skiemenis.

k

K

k

K

ka

ko

ke

ak

ok

ek

Ka

Ko



4. Pasakyk paveikslėlių pavadinimus skiemenimis ir garsais. Įrašyk k.

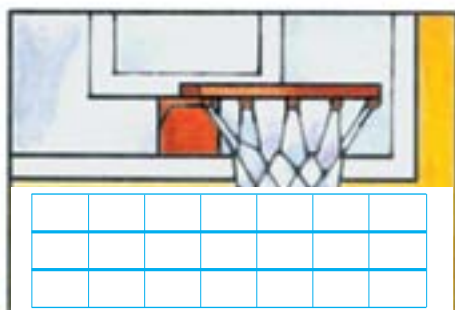
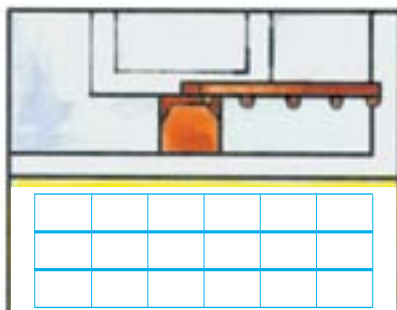
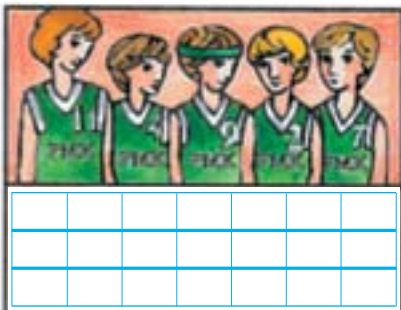



1. Prie paveikslėlių, kur vaikai žaidžia taisyklingai, nupiešk 😊, o prie paveikslėlių, kur vaikai nesilaiko saugaus žaidimo taisyklių – ☹️.



2. Parašyk raides, žodžius ir sakinį.

k K

kalė kėlė

Kostas kėlė.



3. Nuspalvink piešinėlį ir pamatysi, kuo negalima žaisti.

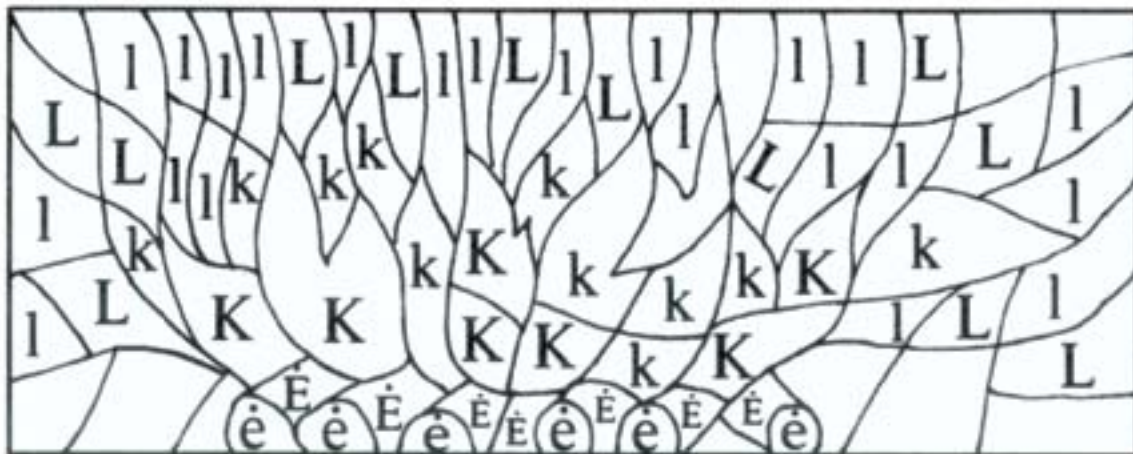

K
k
L
l
É
é



4. Perskaityk žodžius ir parašyk juos po atitinkamais paveikslėliais.





5. Atspėk, kokie žodžiai pasislėpė karoliukuose. Parašyk juos.

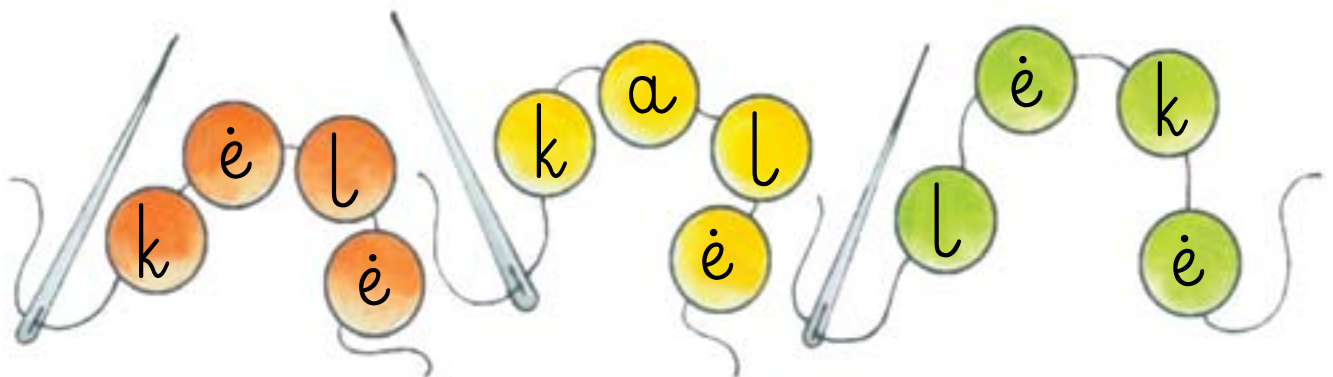



6. Ritmiškai pasakyk sakinį. Išplok ritmus.



7. Nuspalvink kaladėles su raidėmis **k** ir **K**.

Ka	ti	nė	li,	nu	nu	nu!
Ta	ve	bar	ti	ke	ti	nu!



1. Kaip turėtų pailsėti Tomas, o kaip Asta? Kodėl? Pažymėk rodyklėmis.

Tomas mokėsi.

Asta kasė.



2. Kieno kuris žaislas? Nuspalvink žaisliuką, kuriuo tu norėtum žaisti.

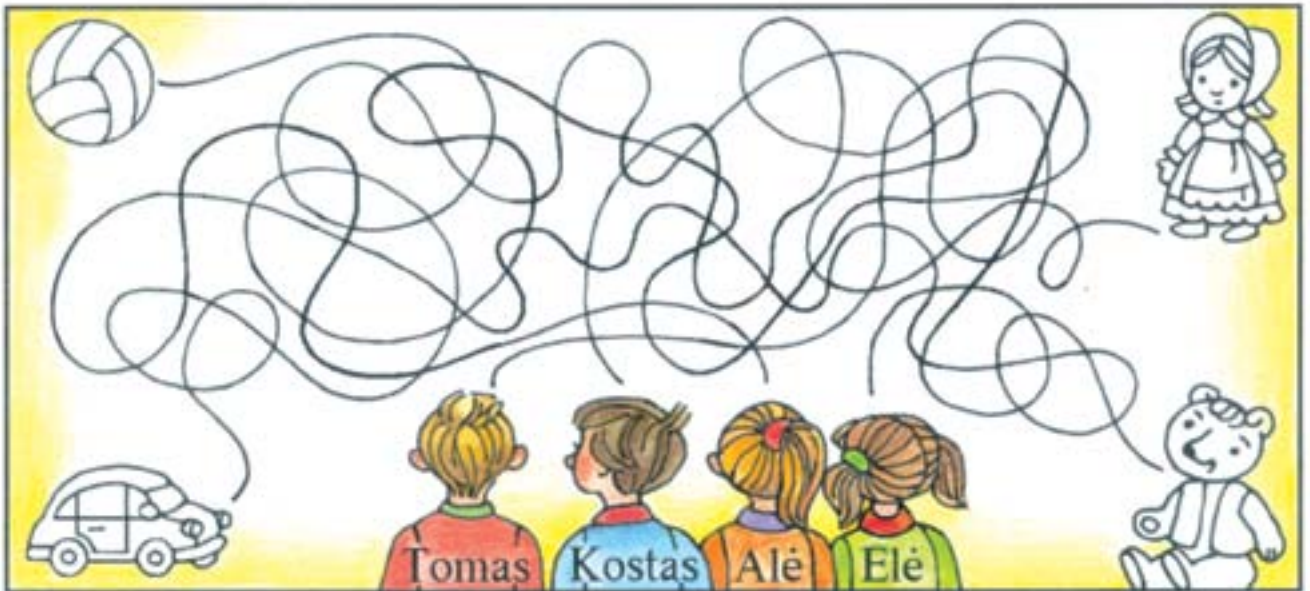

3. Po kiekviena mažąja raide parašyk didžiąją.

a o e t s l m k



4. Žalia spalva pabrauk **K** ir **k**.

koja **K**azys šokdynė klasė kelnės lankas
raketė kėlė vilkas lėkė penki taškas



5. Sutvarkyk pabirusius žodžius ir parašyk klausimams atsakymus.

kasa.

Kosto

mama

Kas kasa?

tėtė

kala.

Tomo

Kas kala?



6. Kaladėles su balsėmis nuspalvink raudonai, o kaladėles su priebalsėmis – mėlynai.



7. Kuriame namely kurios raidės gyvena? Parašyk jas.



8. Nuspalvink dvi tokias pačias mašinėles.

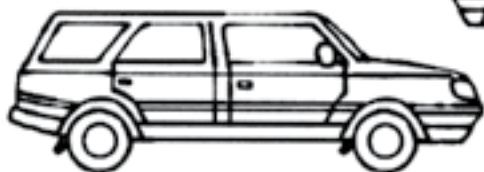

š Š



1. Sujunk paveikslėlius tinkama tvarka. Nuspalvink juos.

š Š



2. Nuspalvink tuos lapus, ant kurių parašyta raidė Š arba š.

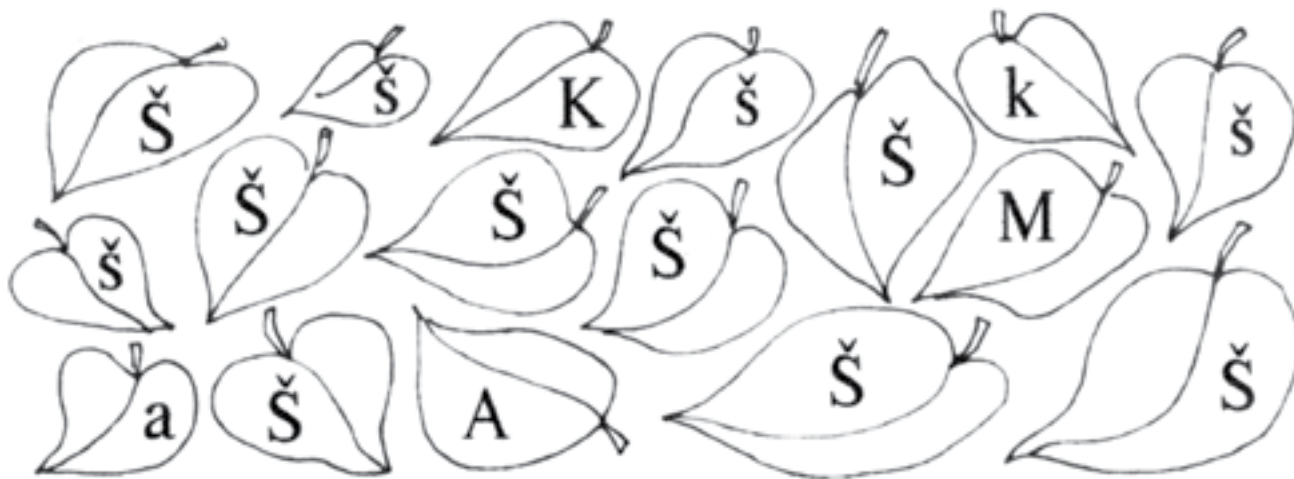

3. Nuspalvink langelius, žyminčius garsą š.

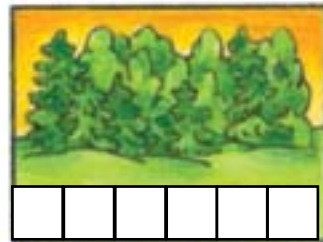
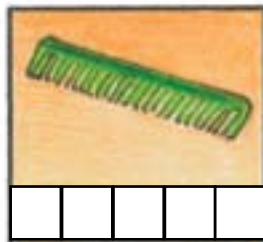
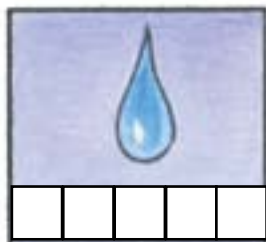
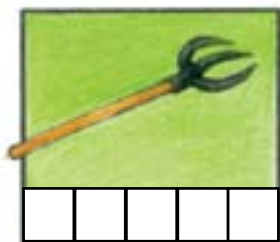

4. Parašyk raides ir skiemenis.

š Š

š Š

ša šo še aš oš eš Ša Šo Še



5. Papasakok, ką žinai apie rudens mėnesius. Tuščiuose trikampiuose nupiešk, kas dar būdinga rudeniiui.



6. Papasakok, kaip raidės **S** ir **s** virto raidėmis **Š** ir **š**.



7. Kurios raidės netinka? Išbrauk jas.



8. Pasakyk paveikslėlių pavadinimus skiemenimis ir garsais. Įrašyk **Š**, **š** ir **s**.

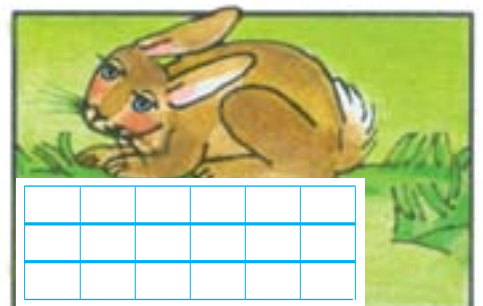
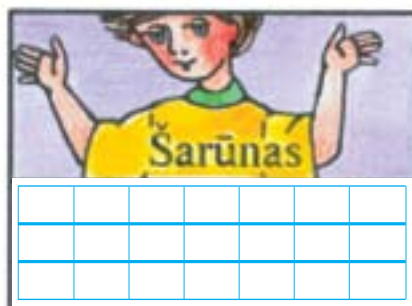
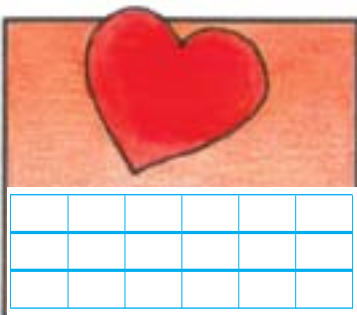



1. Lapus su raidėmis š ir Š nuspalvink geltonai, o su s ir S – rudai. Nuo kokių medžių nukrito šie lapai?

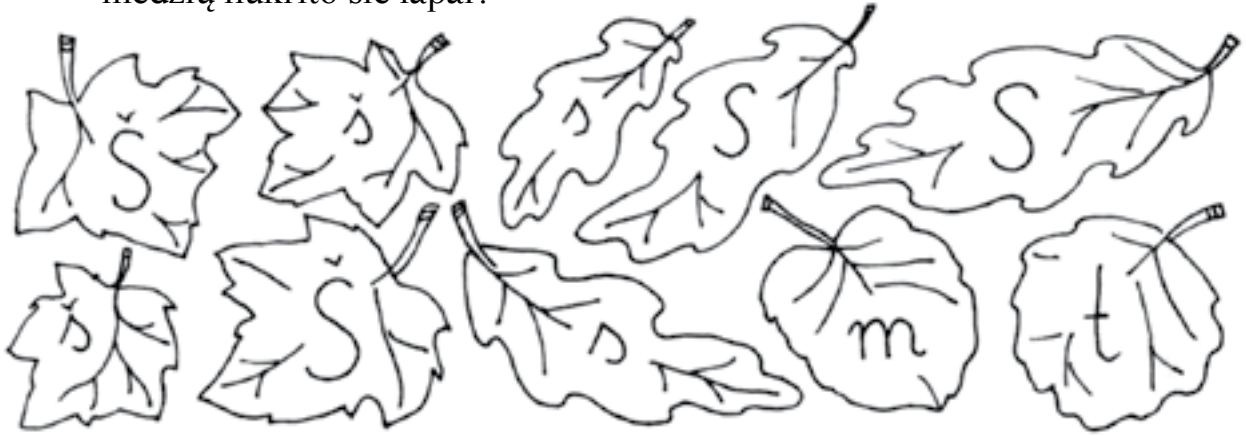

2. Parašyk raides ir žodžius.

š Š
 šaka šoka
 šalo šėlo



3. Sujunk vienodus lašelius – sudaryk sakinius ir parašyk juos šalia atitinkamų paveikslėlių.

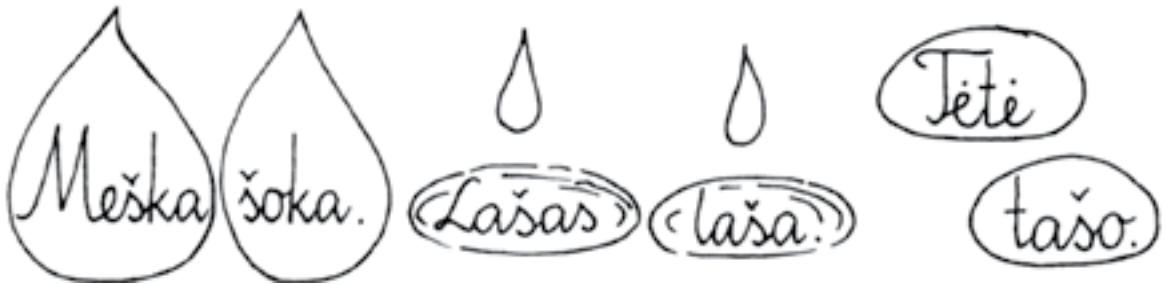



1. Tuos paukščius, kurie išskrenda į šiltuosius kraštus, apibrėžk geltonai, o tuos, kurie pas mus žiemoja – mėlynai. Kuris paukštis liko? Kodėl?



2. Kurie gyvūnai žiemą užmiega? Rodyklėmis nuvesk juos prie pagalvėlės. Tuos gyvūnus, kuriems žiemą reikia padėti, atvesk prie ėdžių.



3. Pasiklydo raidės. Sudaryk iš jų žodžius ir parašyk tinkamuose langeliuose.

<table border="1"><tr><td> </td><td> </td><td> </td><td> </td></tr><tr><td> </td><td> </td><td> </td><td> </td></tr><tr><td> </td><td> </td><td> </td><td> </td></tr></table>													<table border="1"><tr><td> </td><td> </td><td> </td><td> </td></tr><tr><td> </td><td> </td><td> </td><td> </td></tr><tr><td> </td><td> </td><td> </td><td> </td></tr></table>													<table border="1"><tr><td> </td><td> </td><td> </td><td> </td></tr><tr><td> </td><td> </td><td> </td><td> </td></tr><tr><td> </td><td> </td><td> </td><td> </td></tr></table>												



4. Suporuok vaikų batelius ir raštu atsakyk į klausimą. Paryškink didžiąsias raides.



Kas šoka?



5. Nuspalvink: š e k š s .

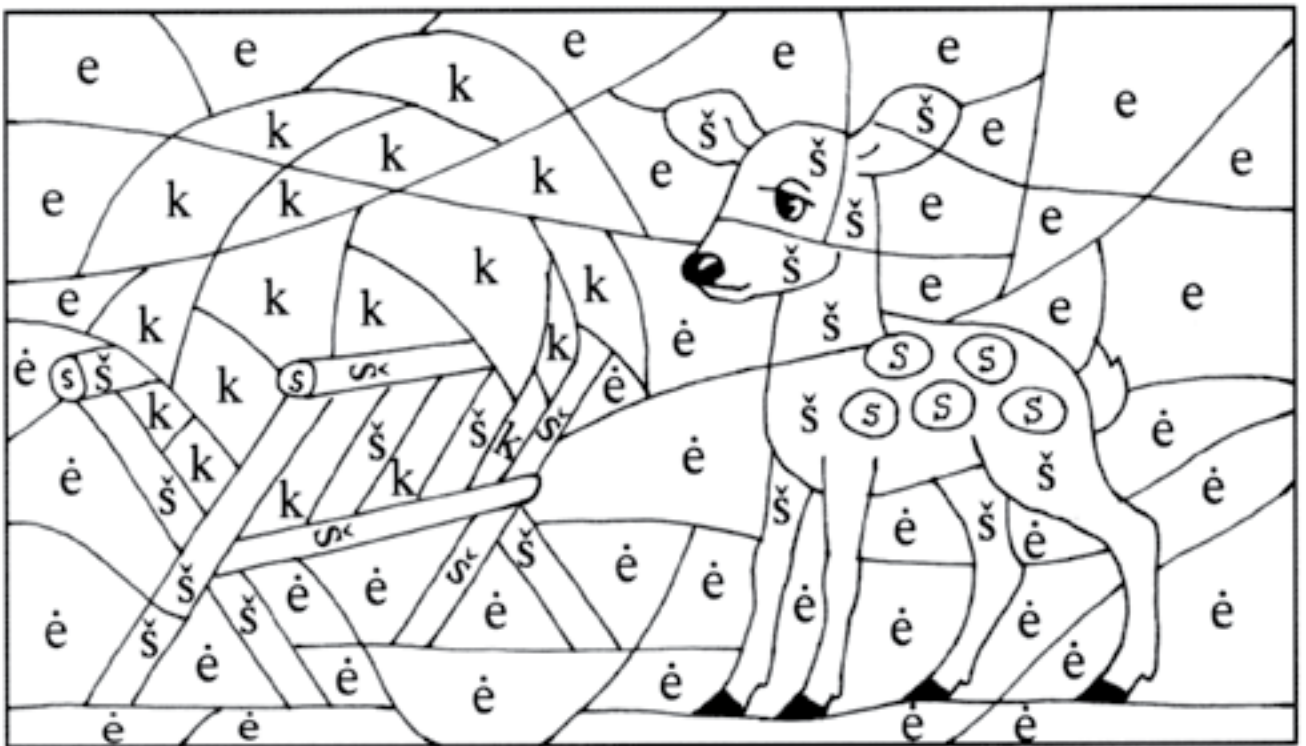

6. Kas su kuo šoka? Pažymėk nurodytomis spalvomis.

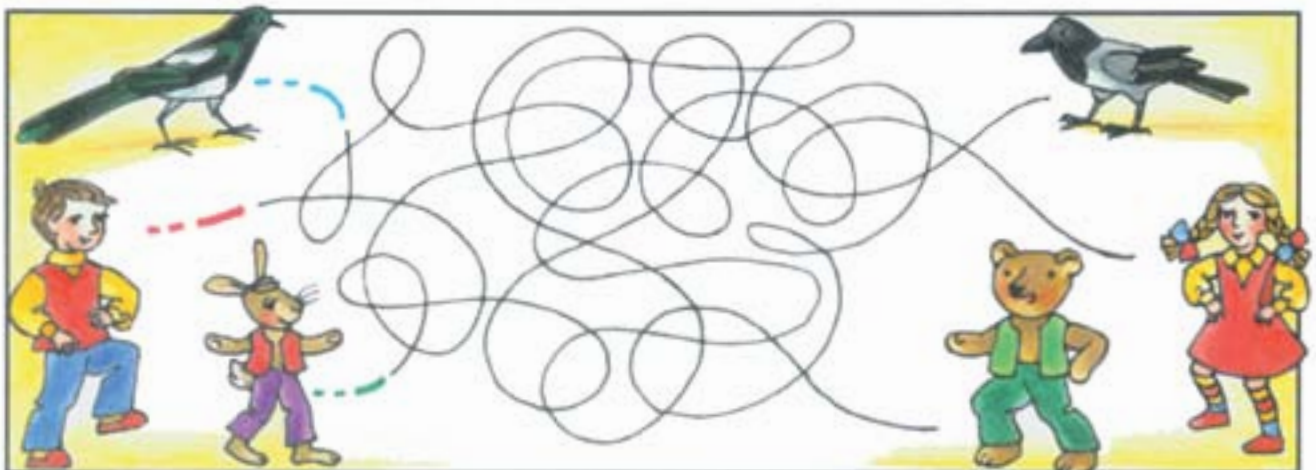



1. Pabaik piešti lesyklėlę. Nuvesk paukštelius į jų užėigą – surink visas raides š ir Š.

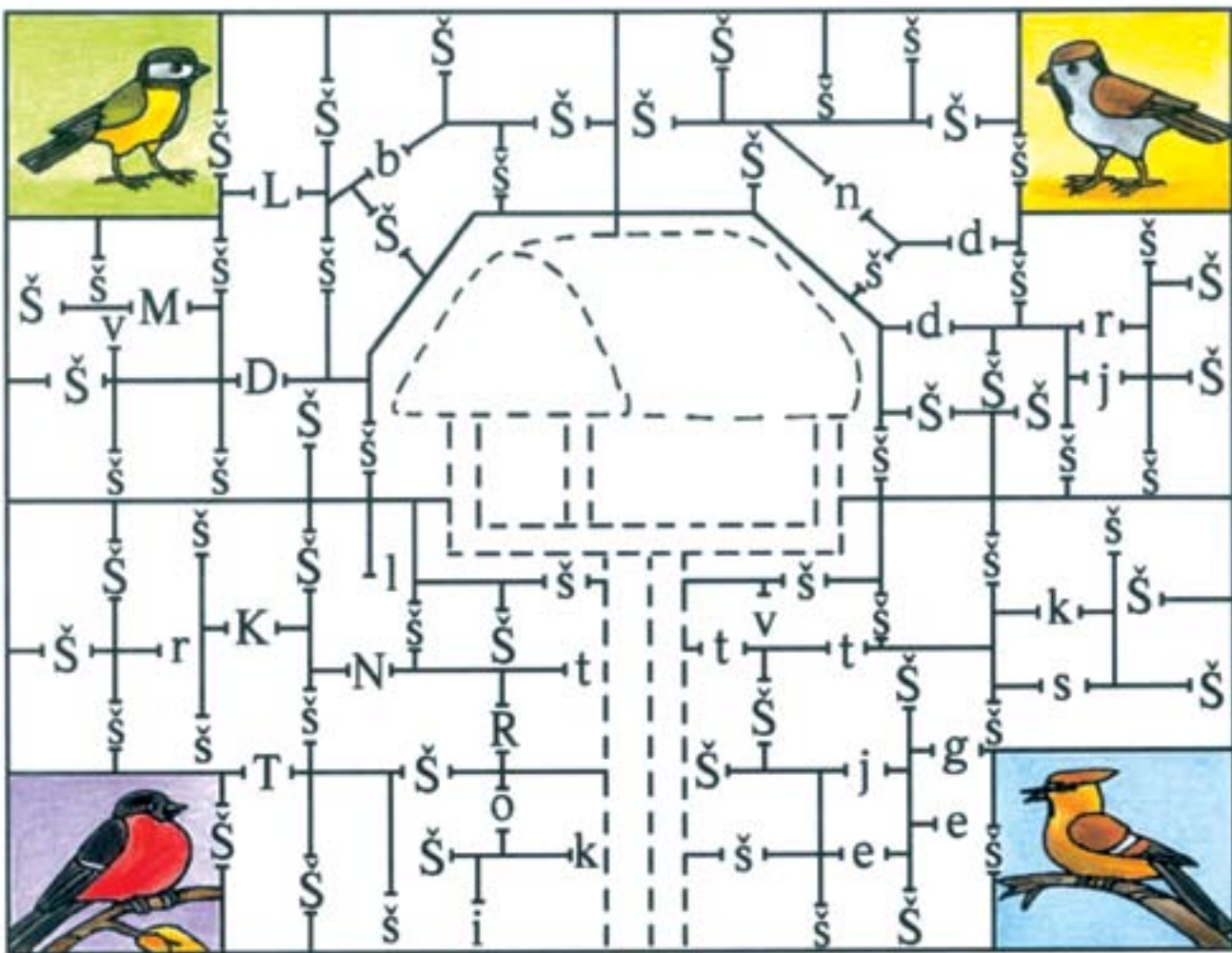

2. Kokius žodžius skaitė kurapkiukai? Ir tu juos perskaityk ir parašyk.

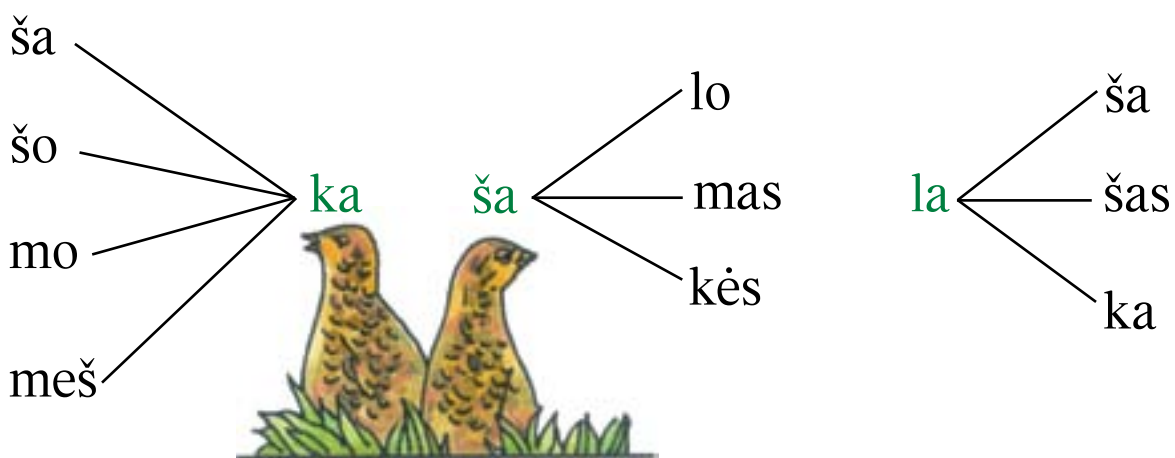



3. Kokį skanumyną kuris paukštelis pasirinks, sužinosi išsprendęs raizgynėlę.

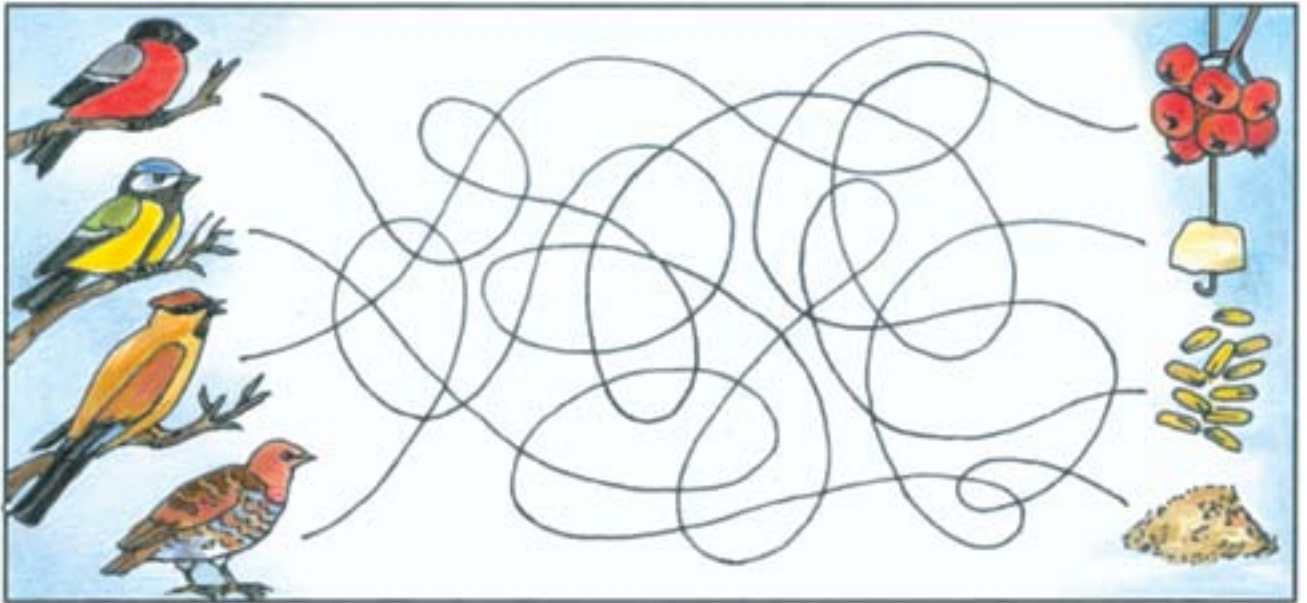

4. Sujunk brūkšnelius ir nuspalvink. Ką žinai apie šiuos paukščius?



5. Paukščių pavadinimuose įrašyk raides, kurias jau pažįsti.

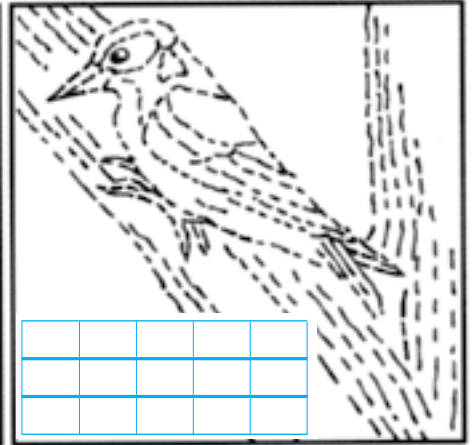
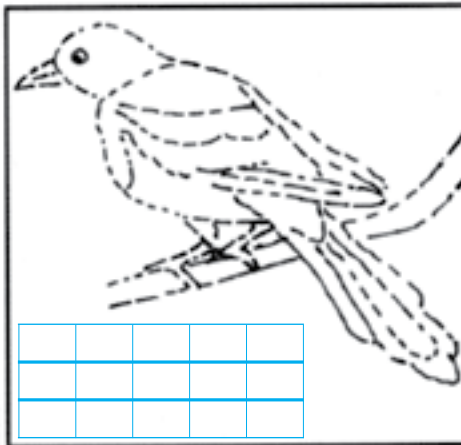
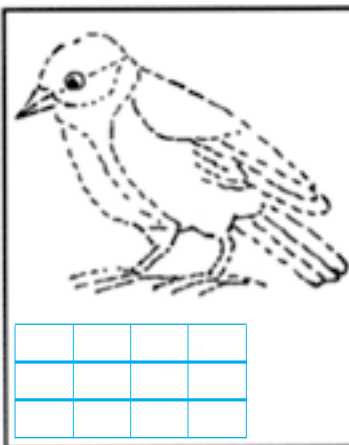

6. Išmok greitakalbę. Pabrauk žalia spalva Š ir š.



7. Baik marginti šaliką.

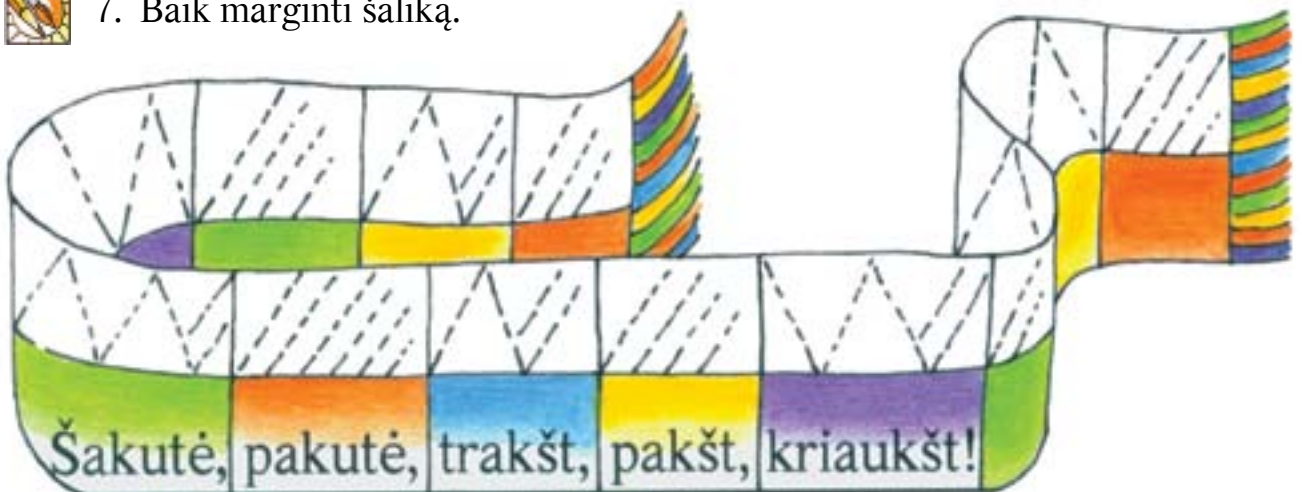

r R



1. Nuspalvink langelius, žyminčius garsą r.

r R

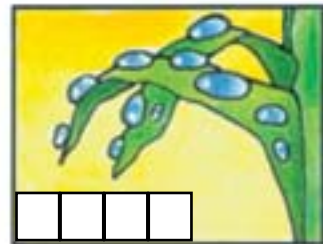
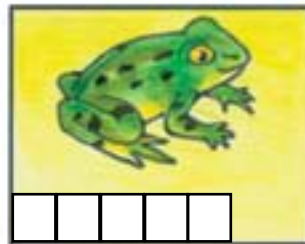
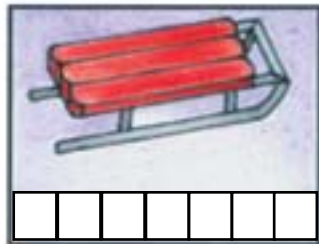

2. Nuspalvink raidėmis R ir r pažymėtas piešinio dalis ir sužinosi Saulutės mišlės įminimą.

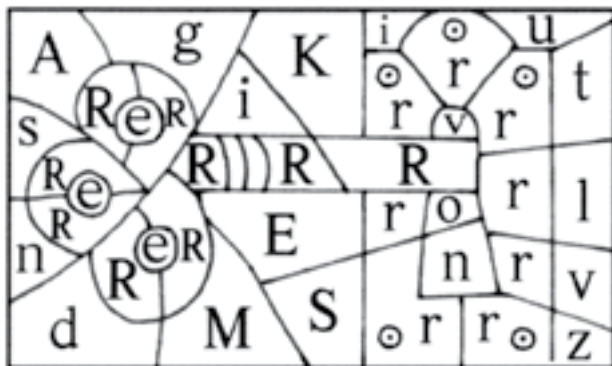

3. Parašyk raides ir skiemenis.

r R

r R

ra ro re ar or er Ra Ro Re



4. Kurios raidės čia netinka? Išbrauk jas.

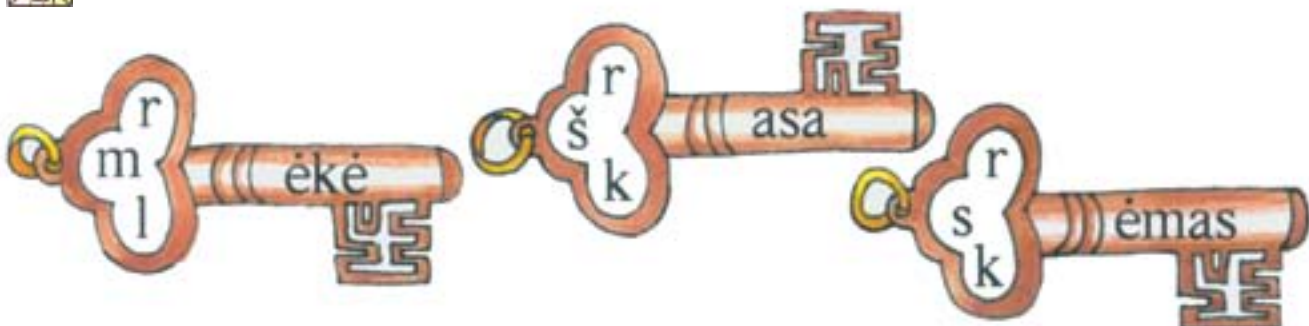



1. Kuriam pasakos veikėjui kuris daiktas tinka? Nurodyk strėlytėmis.



2. Pasistenk pasakiškai gražiai parašyti raides ir žodžius.

r R
 rašo ras
 Rasa Romas



3. Vaikai žaidė žodžių lotą. Perskaityk ir parašyk, kokius žodžius jie sudarė.



4. Nuspalvink kaladėles su raidėmis R ir r.

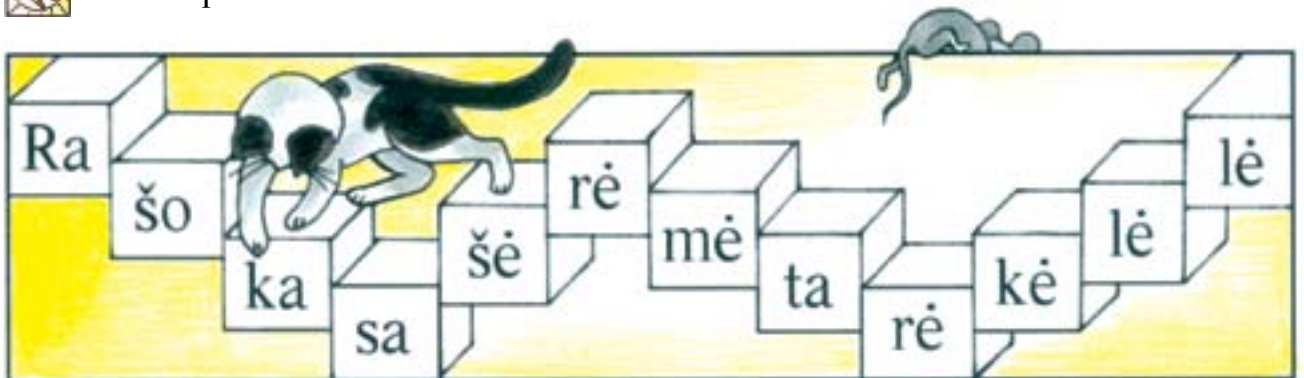



5. Žalia spalva pabrauk **R** ir **r**.

Rimas rūmai Raudonkepuraite kurpė
ragana karalius Rožė ragas pyragas burtai



6. Nuspalvink **r** **R** **š** **Š** ir sužinosi, kur galima rasti daug pasakų.

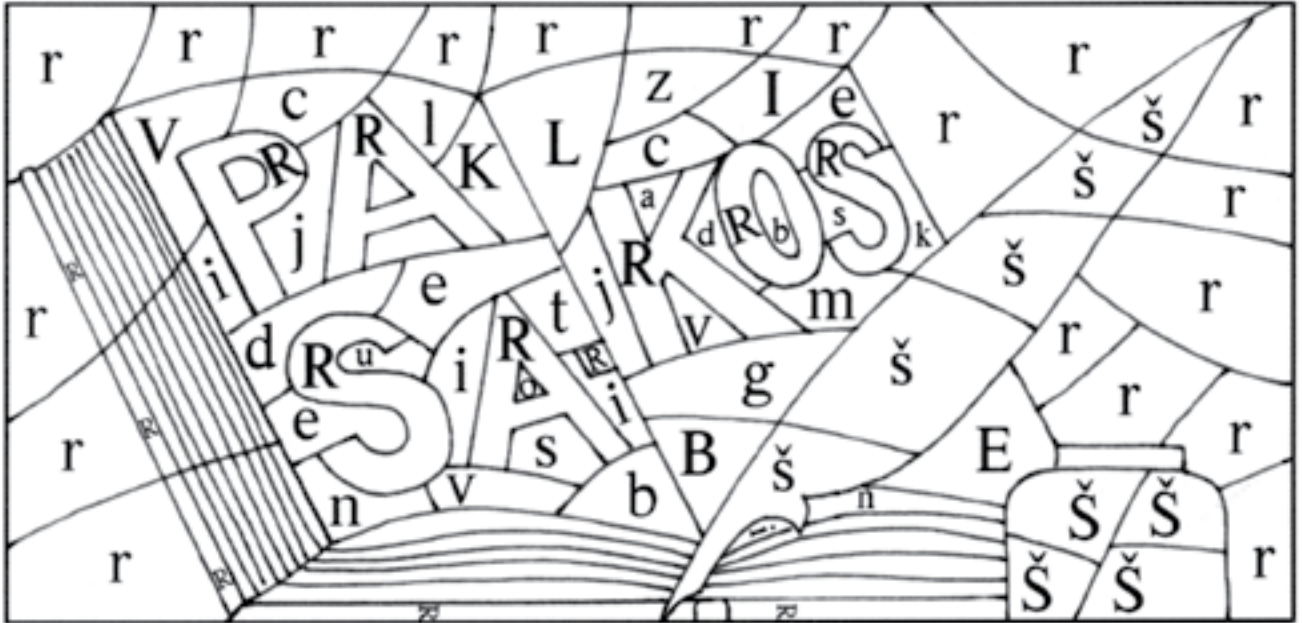

7. Nupiešk labiausiai tau patinkančios pasakos iliustraciją.

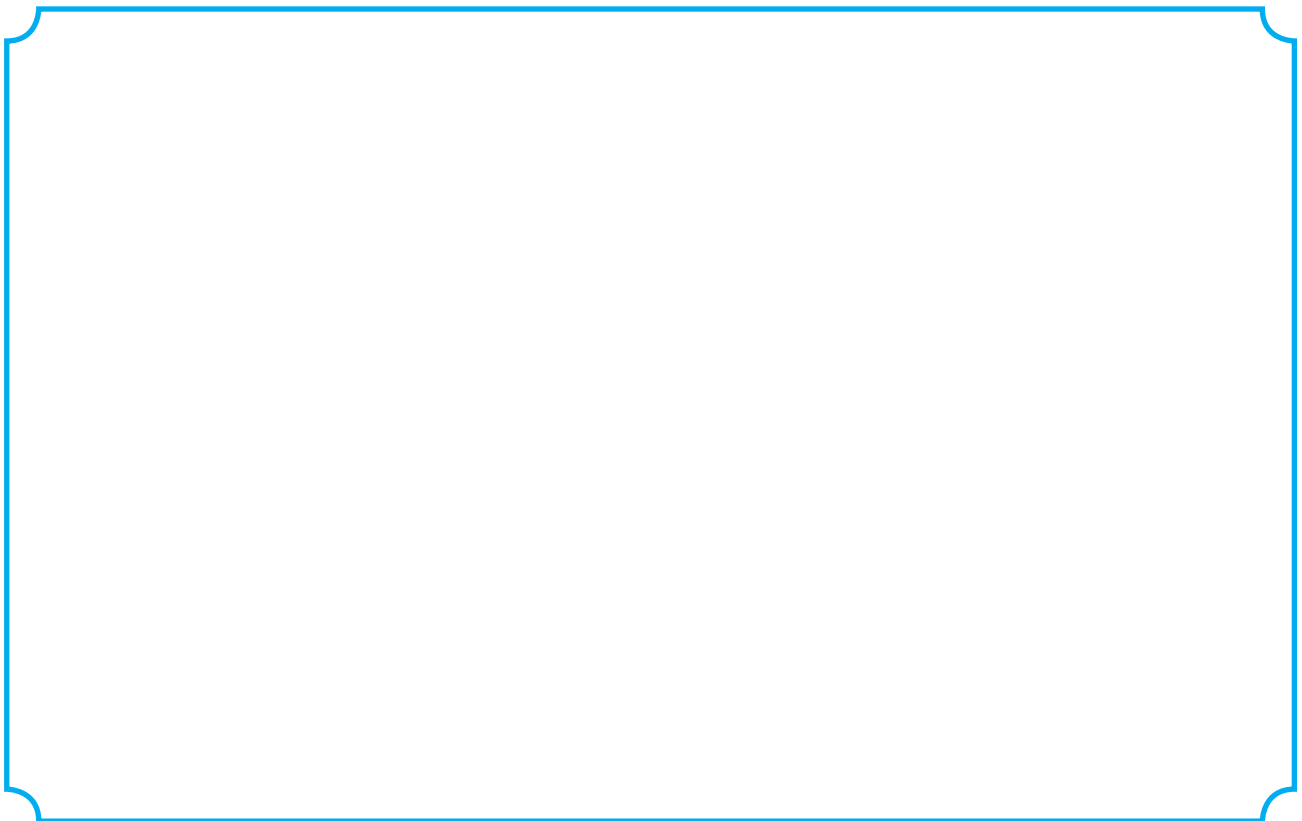



1. Gaidelis raško tik tuos riešutus, kurie pažymėti raidelėmis **R** ir **r**.
Nuspalvink juos.



2. Parašyk, kas ką veikė.

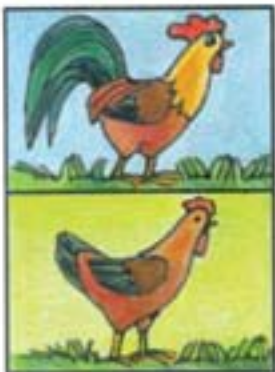



3. Padėk vištelei iš pabirusių raidžių sudaryti žodžius.



rtsaa



aaktrs



ėamrs





1. Varna ieškojo žodžių, kuriuose yra **R** arba **r**. Nuspalvink geltonai piešinio dalis su tais žodžiais. Ką surado varna?

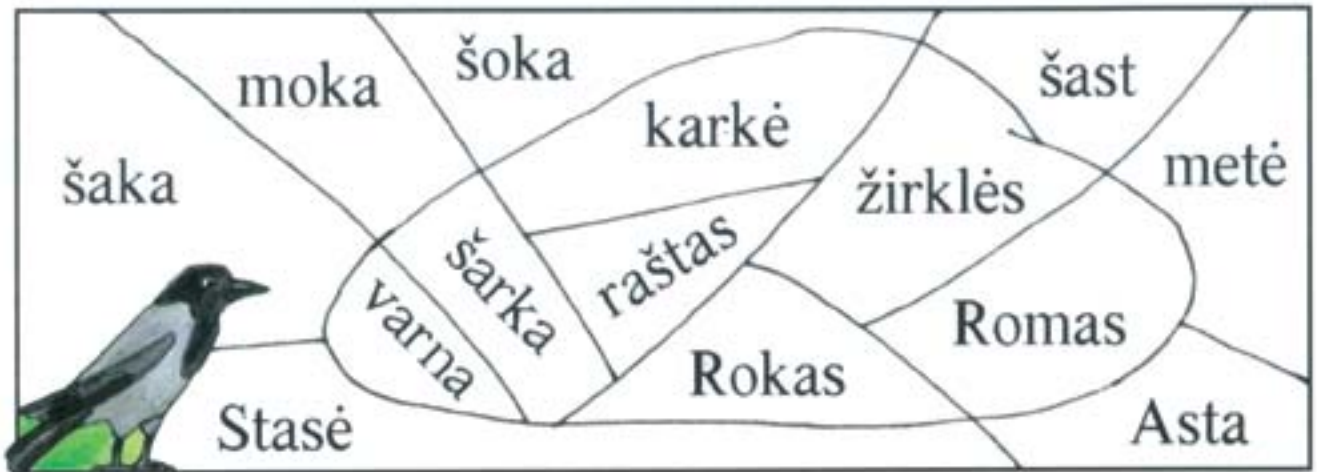

2. Sujunk lapės pėdas. Parašyk sudarytą sakinį.



3. Išspręsk kryžiažodį.

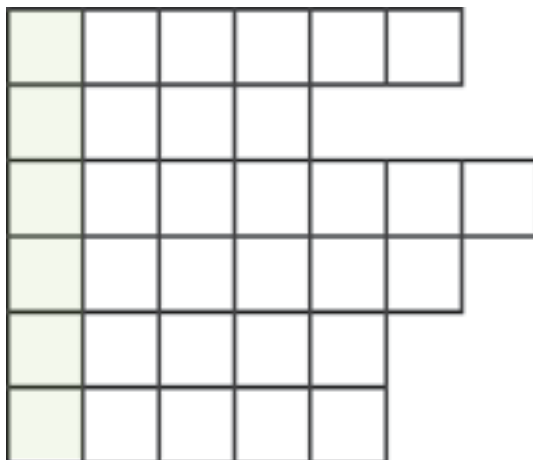

4. Rask raidžių poras. Pažymėk jas spalvotomis rodyklėmis.

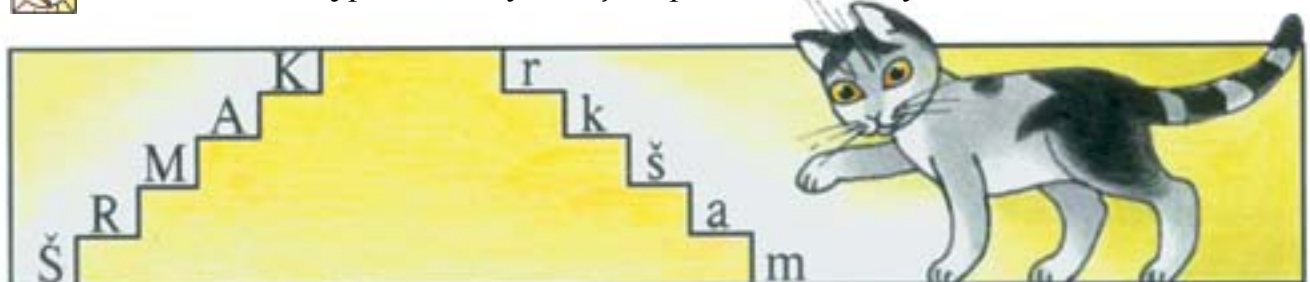

d D

d D



1. Nuspalvink plotelius: d k t .



2. Pavadink paveikslėlių, nuspalvink langelių, žymintį garsą d.

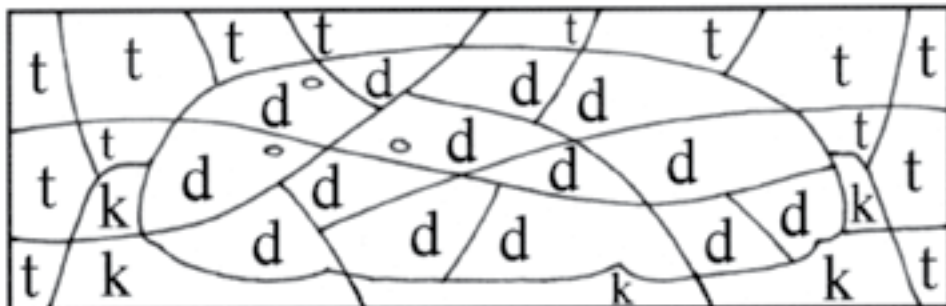

--	--	--	--



3. Parašyk raides ir skiemenis.

d

D

d

D

da de de ad od ed Do De Da



4. Pavadink valgį. Pasakyk pavadinimus skiemenimis ir garsais. Įrašyk d.

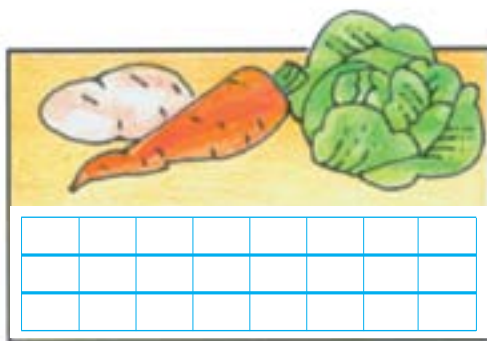
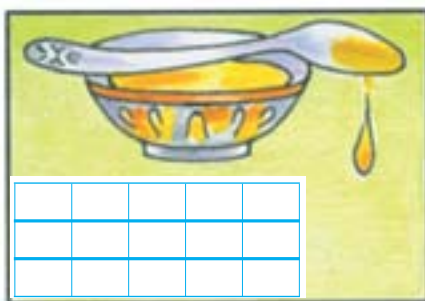
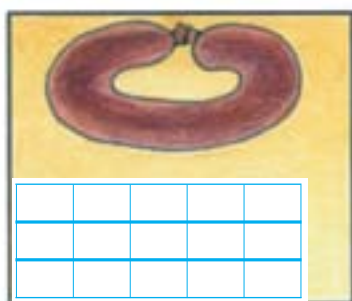

5. Įrašyk raides, kurias moki.
Paryškink didžiąją raidę vardo pradžioje.



Danutė



Domantas



1. Domas darė salotas iš tų produktų, kurių pavadinimuose yra raidė **d**, o Tomas – iš tų, kuriuose nėra **d**. Sudėk juos į dubenis – nubrėšk strėlytes.



2. Pasimokyk rašyti raides ir žodžius.



3. Adomas ras ledus, jeigu eis takeliu, pažymėtu jo vardo raidėmis. Nuspalvink tą takelį.

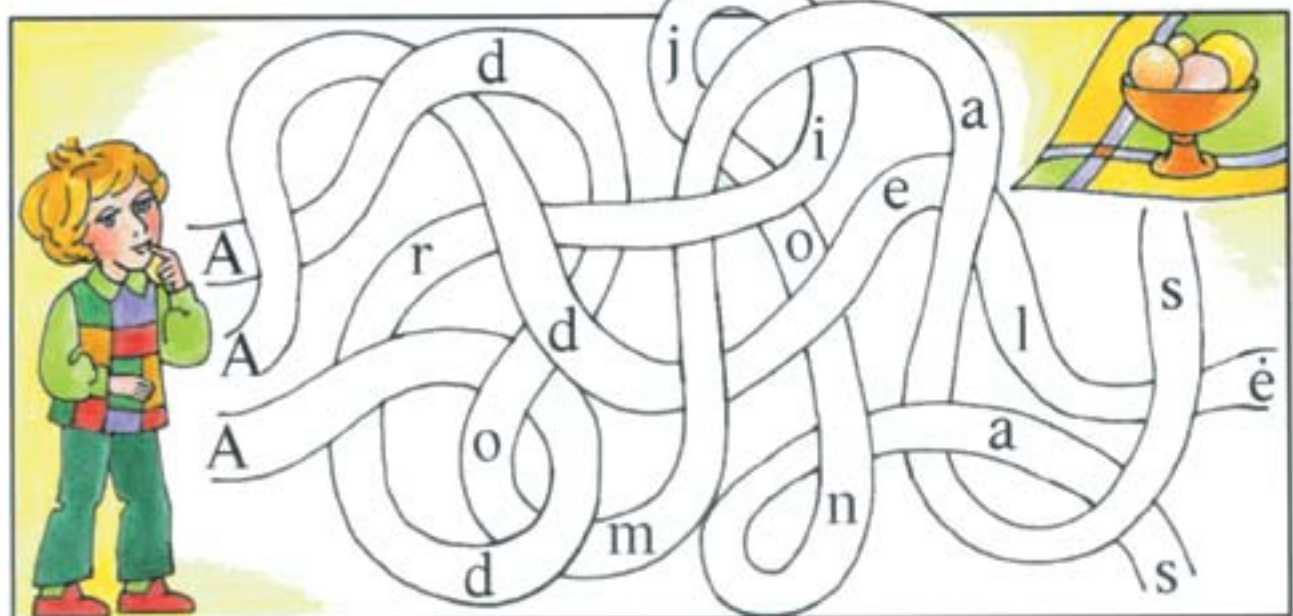



4. Kuo dantukai džiaugtųsi, o dėl ko verktų? Nurodyk rodyklėmis.



5. Pavadink šiuos daiktus. Nuspalvink tuos, kurių pavadinimuose girdi garsą **d**.



6. Nupiešk ir pagražink.

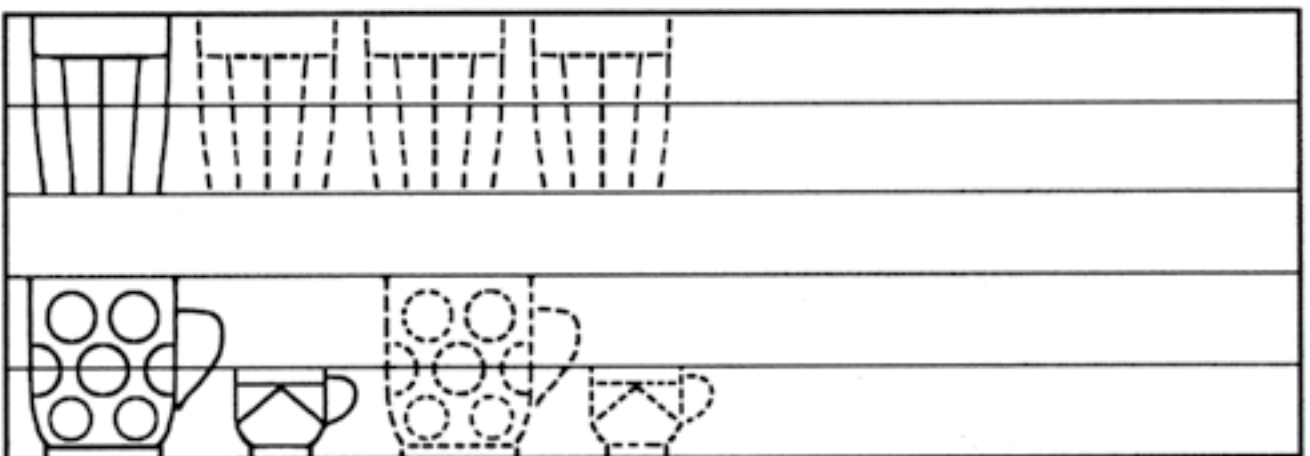



1. Kurie daiktai netinka raidei **d**? Išbrauk juos.



2. Perskaityk skiemenimis parašytus žodžius. Pritaikyk juos paveikslėliams ir parašyk.

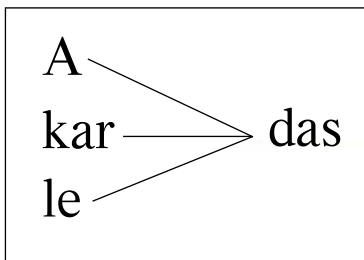

3. Pabrauk patarlių raides taip, kaip prašo Saulutė.

Darbas žmogų giria.
Darbas gėdos nedaro.



4. Pabaik piešti duoną, batonus, pyragus.

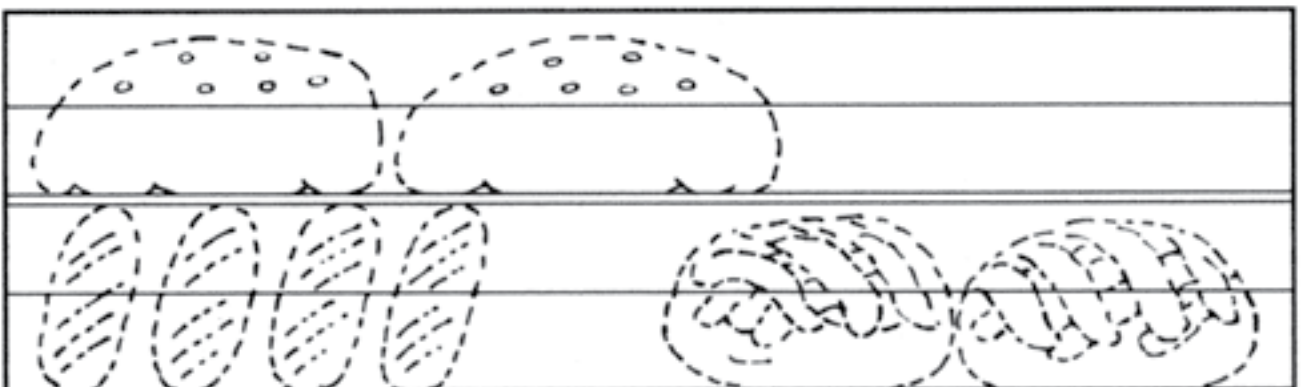



1. Kas elgiasi gerai, o kas blogai? Nuspalvink tą piešinėlį, kuriame vaikas elgiasi gerai.



2. Kuriuo įrankiu valgysi sriubą, žuvį, tepsį sviestą, maišysi arbatą?

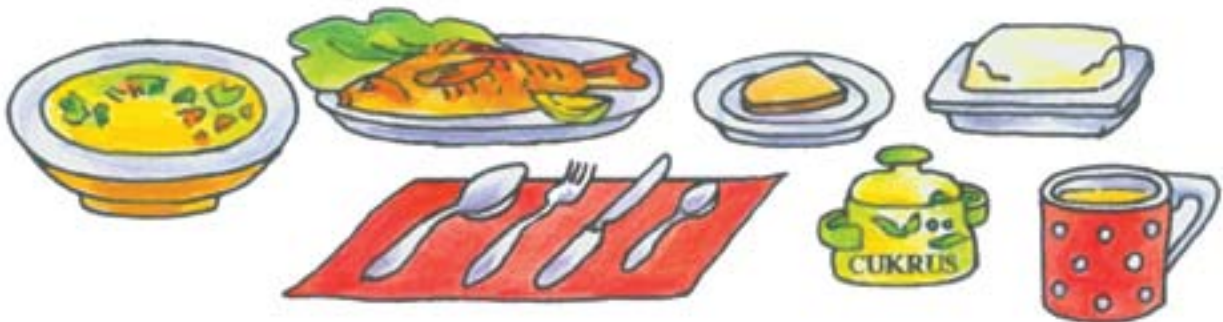

3. Iš pabirusių žodžių sudaryk ir parašyk sakinius.





b B



1. Birutė dės į katiliuką bulves, pažymėtas raidėmis B arba b. Nuspalvink jas.

b B

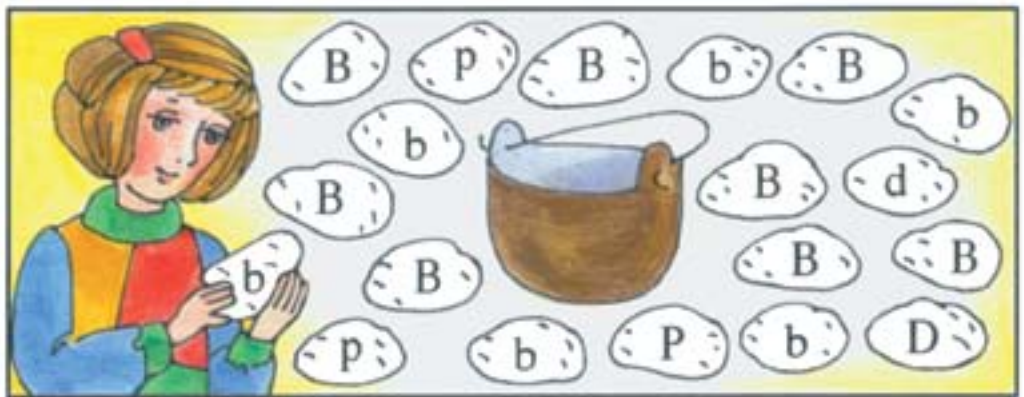

2. Parašyk raides ir skiemenis.

b B

b B

ba be be ob eb Bo Be Ba Be



3. Pasakyk pavadinimus skiemenimis ir garsais. Įrašyk raides, kurias moki. Paryškink b.

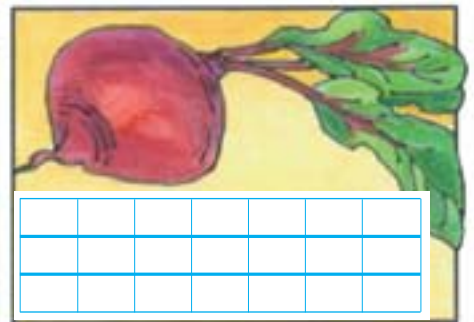
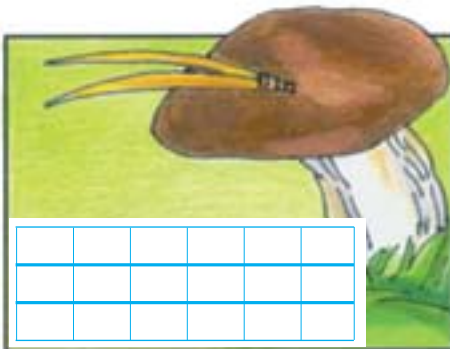
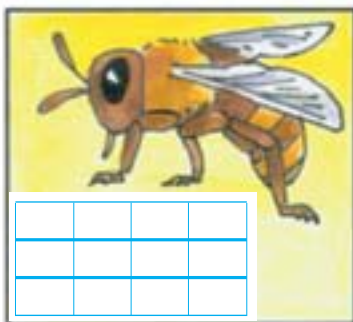

4. Įrašyk raides, kurias moki. Paryškink didžiąją raidę vardo pradžioje.



Balys



Barbora



1. Barbė pavaišino drauges skanėstais, kurių pavadinimuose yra raidė **b**. Strėlytėmis sudėk juos ant stalo.



2. Parašyk raides ir žodžius.

b B

barė bėrė braškė dabar Barbora



3. Nuspalvink: **b** **d** **a**. Kuo groja Birutė, o kuo Danutė?



4. Pasakyk nuspalvintų instrumentų pavadinimus. Į langelius įrašyk raides, kurias jau pažįsti.

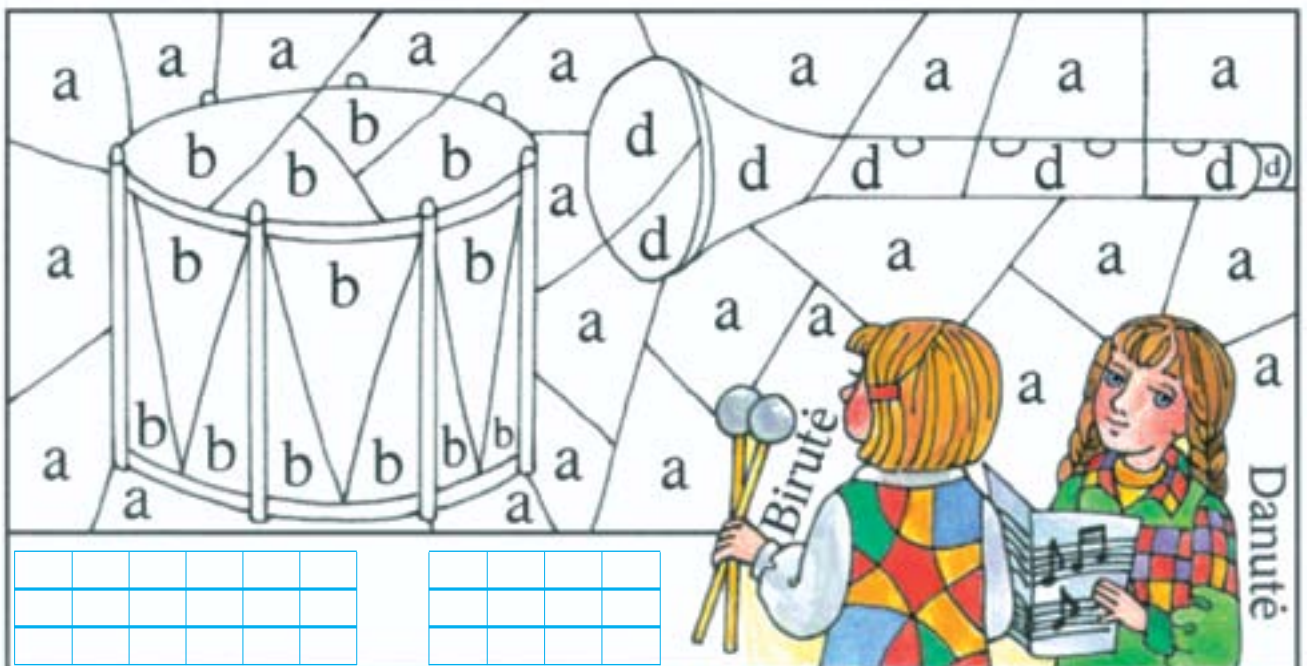



1. Nuspalvink geltonai tuos laukelius, kuriuose esantys žodžiai prasideda raidėmis **B** arba **b**. Visas **B** ir **b** pabrauk mėlynu pieštuku.

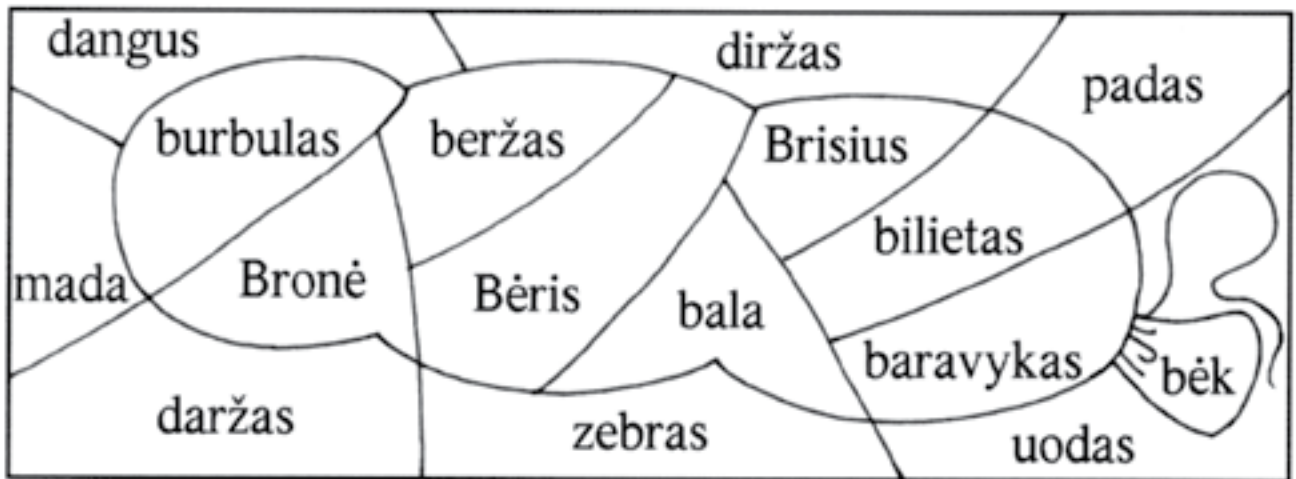

2. Perskaityk gyvūnų pavadinimus ir parašyk juos.



3. Nuspalvink gyvūną, kurio pavadinime nėra raidės **b**.



4. Sudaryk ir parašyk sakinį. Paryškink didžiąsias raides.



u U



1. Nuspalvink langelius, žyminčius garsą u.

u ū

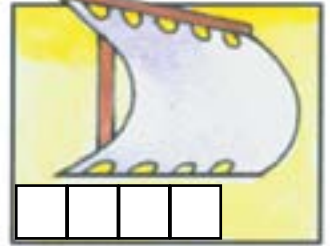
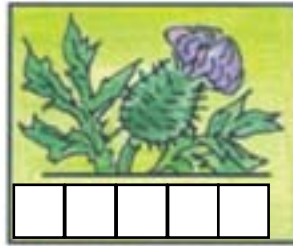
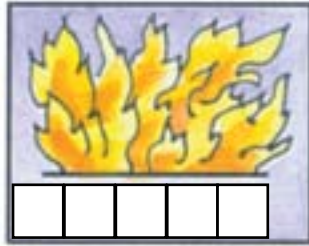

2. Pasakyk skaičiuotę taip, kaip nurodyta kaladėlėse.



3. Pabrauk u mėlynai.

Skur	lum	bur	lum,	tu	tu	tu	tu.	Pūkšt!
------	-----	-----	------	----	----	----	-----	--------



4. Parašyk raides, skiemenis ir žodžius.

u ū

u ū

ul um ur us lu su Ud bus tu kur



5. Kuris vaikas kokį žiemos žaidimą mėgsta?

Astutė

Aldutė

Tomukas

ū Ū

ū ū



1. Nuspalvink langelius, žyminčius garsą ū.

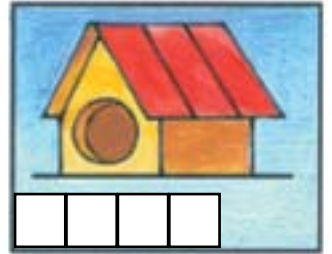
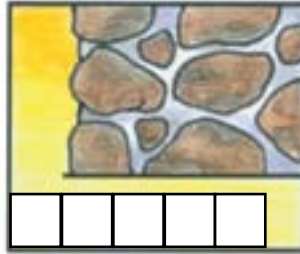
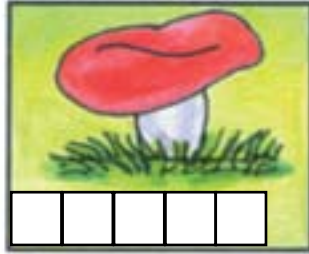

2. Šis magnetas pritraukia tik tuos daiktus, kurių pavadinimuose yra ū. Kurie tai daiktai? Nurodyk strėlytėmis.



3. Rask ir nuspalvink raudonai visas Ū ir ū.

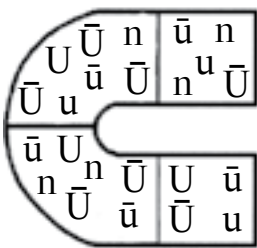

4. Parašyk raides, skiemenis ir žodžius.

ū

ū

ū

ū

ūm ūr ūs lū sū ūd ūsas ūla



5. Perskaityk žodžius ir parašyk juos po atitinkamais paveikslėliais.

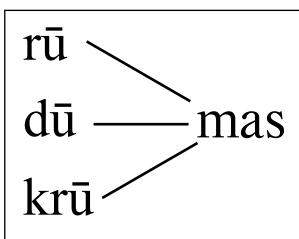



1. Kurie vaikai žaidžia nesaugiai? Nuspalvink piešinėlį, kuriame vaikai laikosi saugaus žaidimo taisyklių.

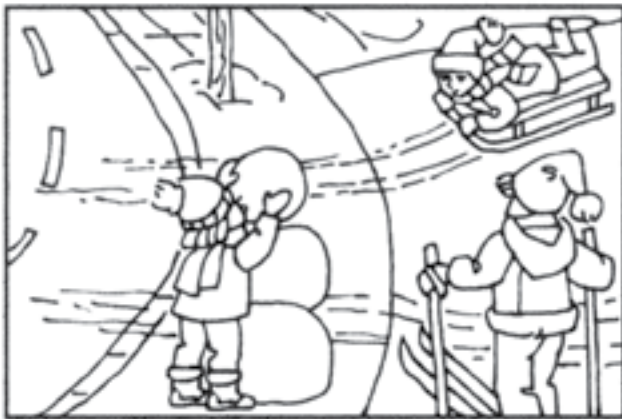

2. Parašyk raides ir žodžius.

ū ū

Mūras dūda būda Rūta Ūmėdė



3. Sujunk rogutes į traukinuką. Sudaryk ir nurašyk sakinį.

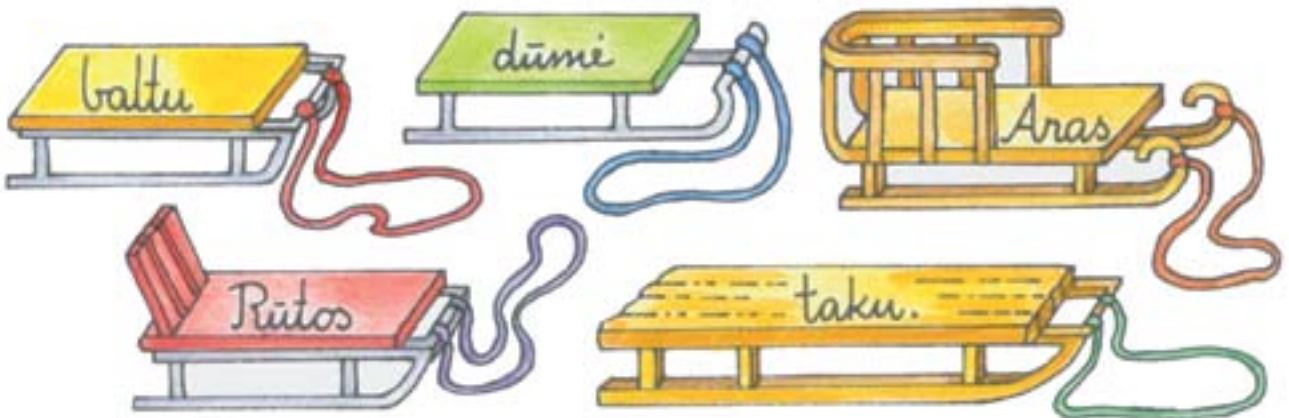

4. Raudonai pabrauk Ū ir ū.

Arūnas Ūglys kopūstas bijūnas Ūdra Ramūnas
Šarūnas liūtas būgnas grūzdas jūra drūtas

v V



1. Nupiešk tiek taškelių, kiek žodyje yra garsų. Apibrėšk taškelį, žymintį garsą v.

v V

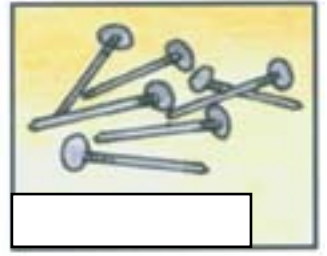

2. Parašyk raides, skiemenis ir žodžius.

v V

v V

va vu vē uv av Va Vė Vu

varlė Valė



3. Sujunk gyvūnus su jų žiemojimo vietomis.





1. Papasakok apie žiemą miške. Pabaik piešinį.



2. Parašyk raides ir žodžius. Žodžiuose spalvotu pieštuku paryškink **v** ir **V**.

v U
 Uoras valo voverė drevė urvas



3. Kokius žodžius sugalvojo voveraitė? Perskaityk ir parašyk.

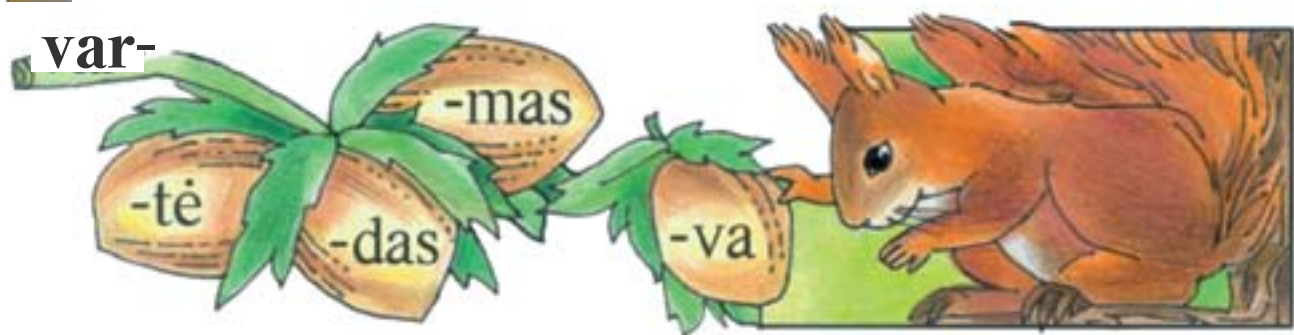

4. Nuspalvink tik tuos vagonus, kuriuose važiuoja žodžiai su **V** arba **v**.

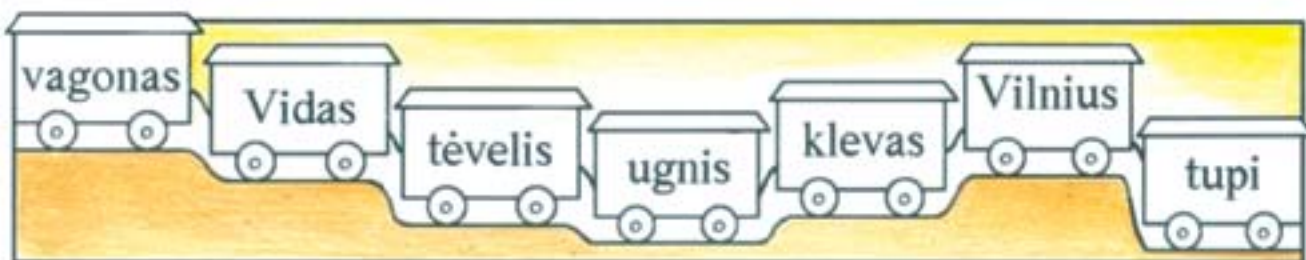



1. Parvesk ožkelę pas ožiukus, o vilką nuvesk pas kalvį – perskaityk ir parašyk dviejų ožiukų vardus. Paryškink didžiąsias raides varduose.

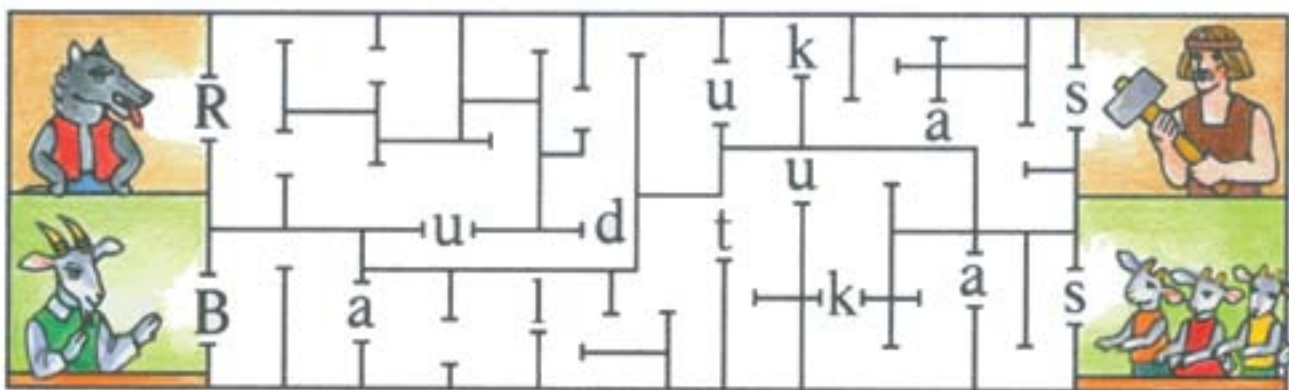

2. Padėk ožiukui perskaityti ir parašyti žodžius.

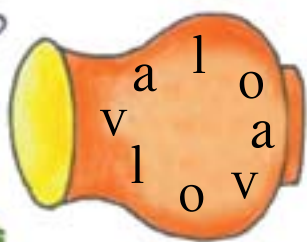



3. Sustatyk ožiukus tokia tvarka, kad žodžiai sudarytų sakinį. Sakinį parašyk.

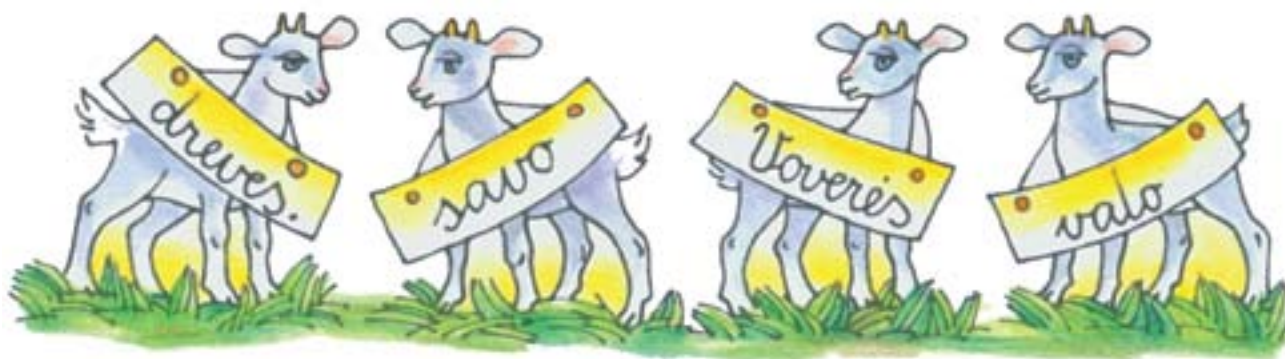



4. Mėlyna spalva pabrauk **V** ir **v**.

Varėna vilkas kalvis Vilma vijūnas Vėjas lėktuvas
vaga Vijo Jonava žvelgė valgė žvaigždė Vaiiva



1. Išbrauk kas antrą raidę, ir sužinosi, kokios šventės artėja. Parašyk švenčių pavadinimą didžiąja raide.

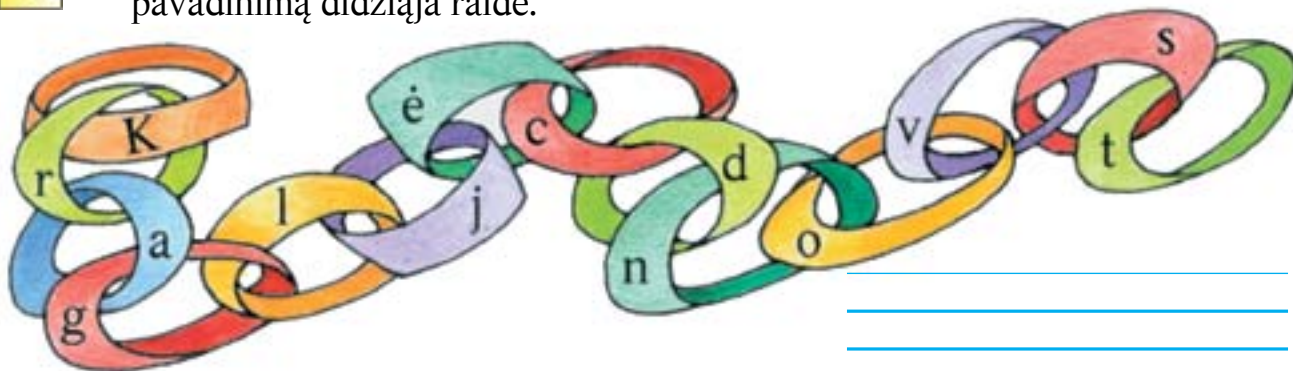

2. Nuspalvink piešinėlį taip, kaip nurodyta. Pavadinink eglutės papuošalus.

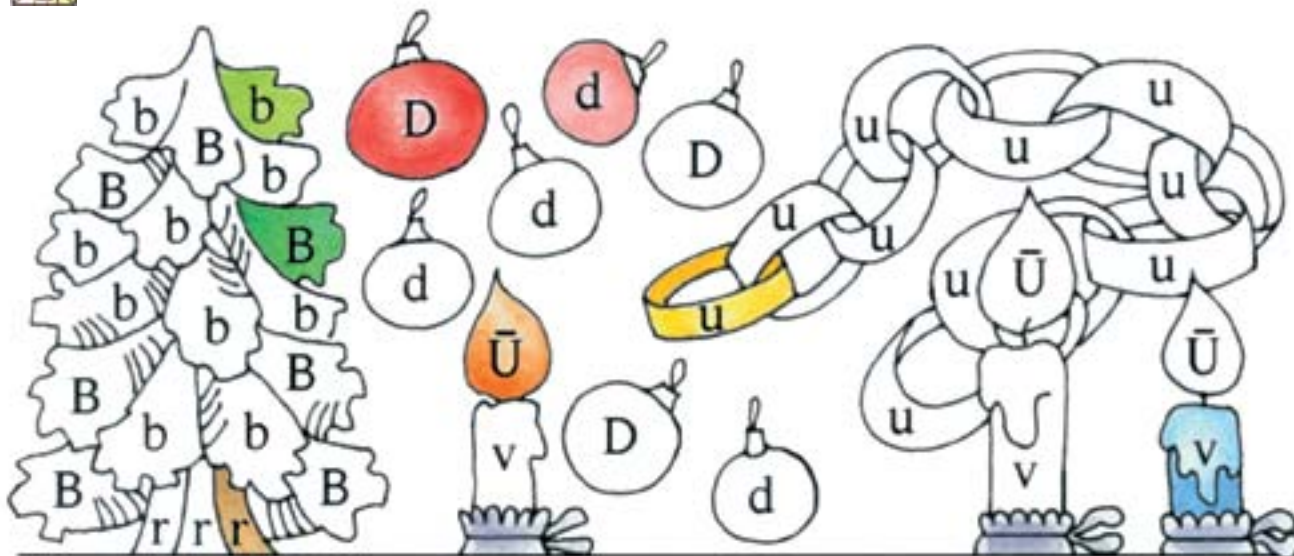

3. Apvedžiok.

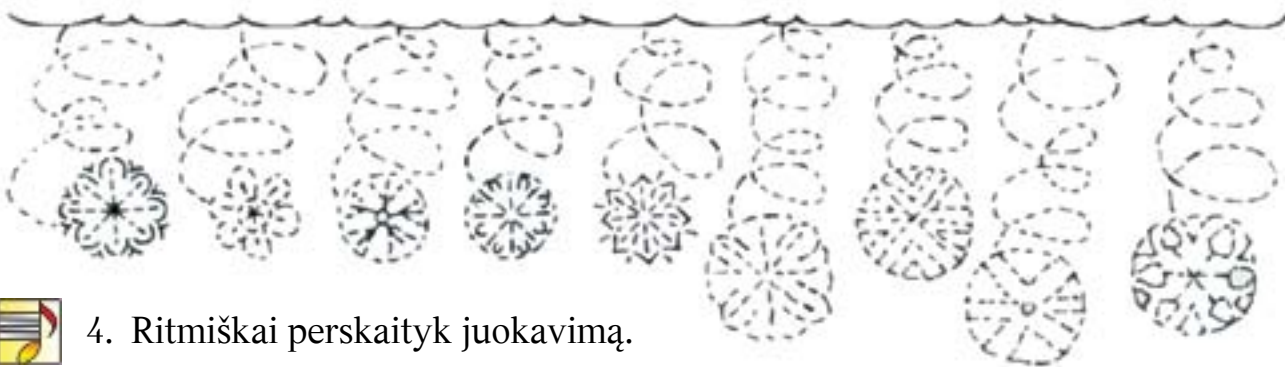

4. Ritmiškai perskaityk juokavimą.



5. Nurašyk juokavimą.

Bė	dos	bė	dos,	kad	Ka	lė	dos.
----	-----	----	------	-----	----	----	------



1. Nuspalvink prakartėlę. Ką ji vaizduoja?



2. Kuris vaikas kokią dovaną ras po eglute?



3. Išspręsk raizgynėlę ir įrašyk sakinių pradžias.

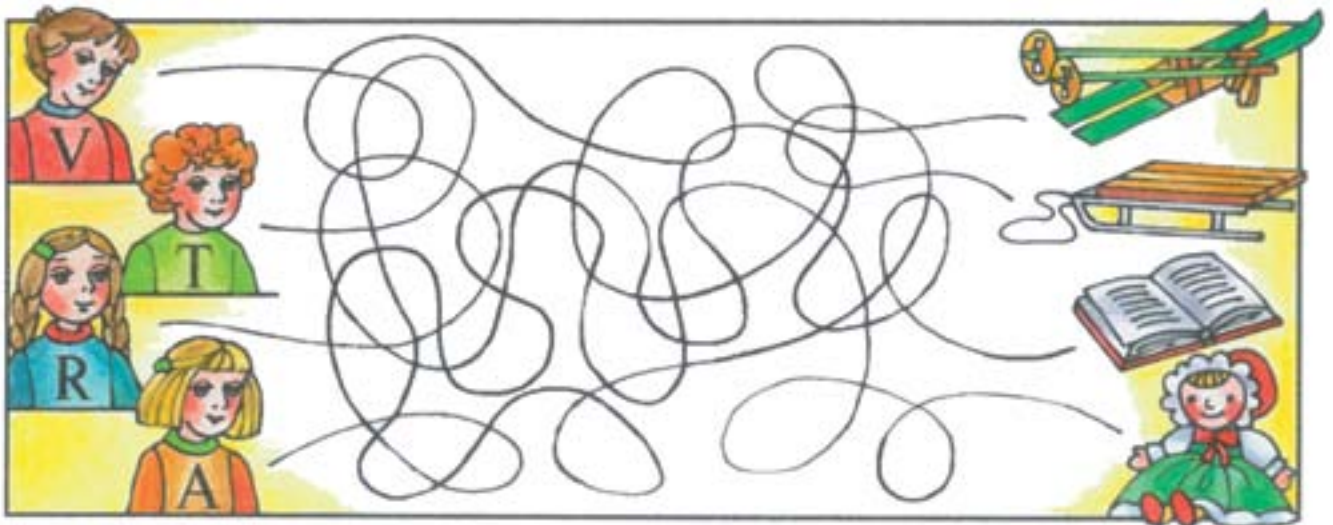

Tomas ras

Valdas rado

Rasa ras

Asta rado







1. Baik piešti piešinėlį. Kokią šventę jis vaizduoja?



2. Nuspalvink laikrodžius, kuriuos galima nešioti ant rankos. Kam skirti kiti laikrodžiai?

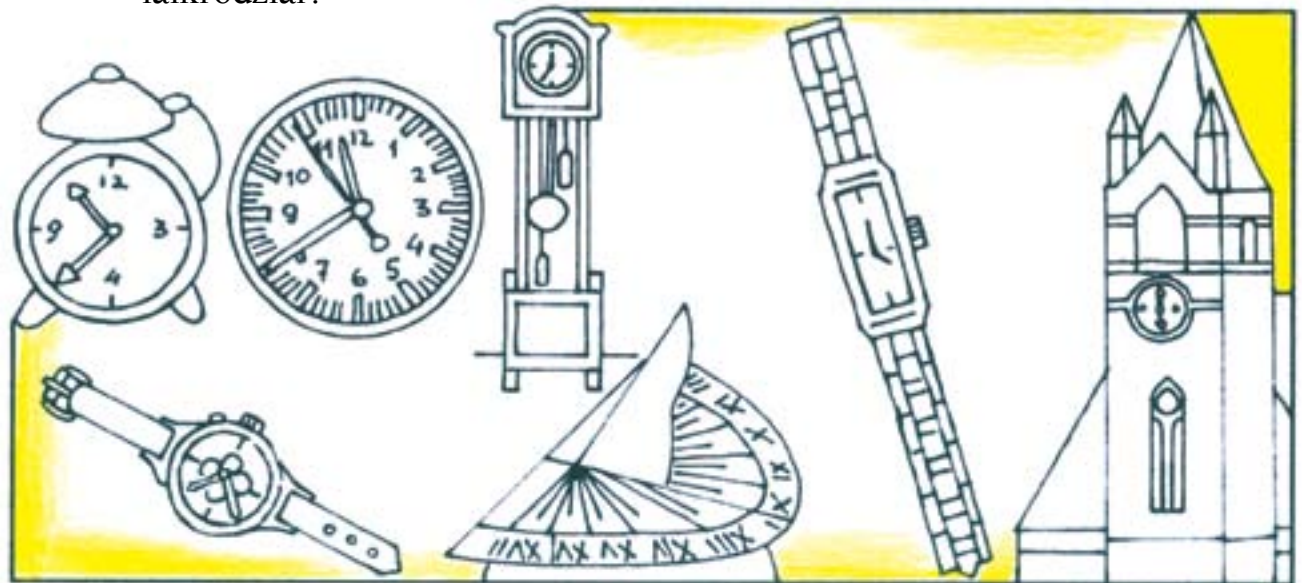

3. Surask tokias pačias žvaigždutes – sudaryk ir parašyk žodžius.



 1. Sudaryk savo veiklos planą. Sujunk savaitės dienų pavadinimus su daiktais. Jeigu kurio nors piešinio tau trūksta – nupiešk.

 2. Savaitės dienų pavadinimuose nuspalvink: **P** **T** **S** **Š** **D** **A**.

PIRMADIENIS

ANTRADIENIS

TREČIADIENIS

KETVIRTADIENIS

PENKTADIENIS

ŠEŠTADIENIS

SEKMADIENIS



 3. Kuris ženklelis kurį metų laiką vaizduoja? Sujunk juos su atitinkamais piešiniais.

 4. Nuspalvink paveikslėlį, kuriame pavaizduotas dabar esantis metų laikas.



 5. Sudaryk ir nurašyk sakinį.



n N



1. Nuspalvink langelius, žyminčius garsą n.



n N



2. Pabrauk mėlynai N ir n.

Navinykai naras Nerutė senelis mano knyga



3. Parašyk raides, skiemenis ir žodžius.

n N

n N

na no nu ne an on Na Ne

namas Nerutė



4. Padėk Tomui ir Rasai grįžti namo. Kuris vaikas gyvena kaime, o kuris mieste?

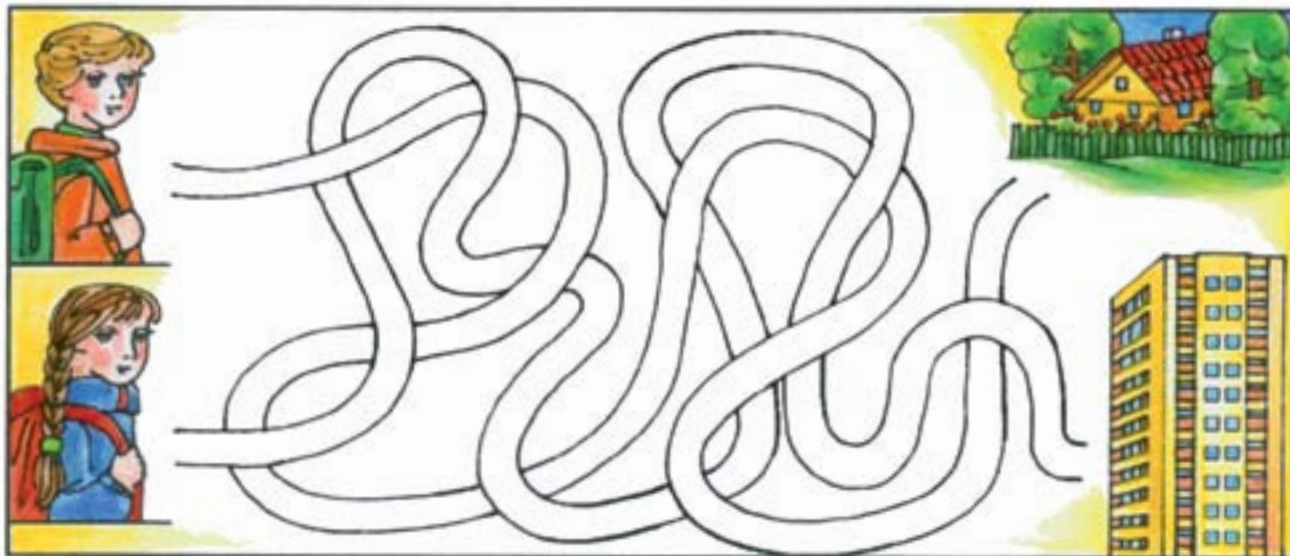



1. Nuspalvink: **M** **m** **N** **n** **U** **u** **Ū** **ū**.

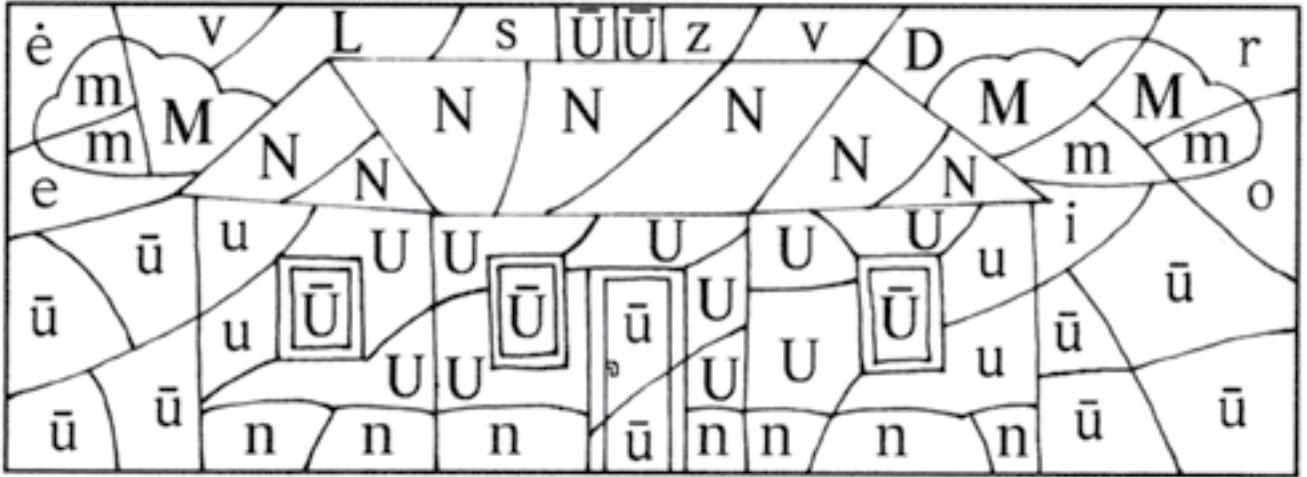

2. Parašyk raides ir sakinį.

n N

Mano namas - mano turtas.



3. Kokie žodžiai pasislėpė nameliuose? Parašyk juos.



4. Kuriuose žodžiuose girdi garsą **m**, o kuriuose **n**? Išbrauk nereikalingą raidę.



i I



1. Nupiešk tiek taškelių, kiek žodyje yra garsų. Apibrėžk taškelį, žymintį garsą i.

i J



2. Parašyk raides, skiemenis ir žodžius.

i J

i J

vil nil oi il in Iu Iš

inkilas Iute



3. Parvesk gyvūnėlius namo.





1. Kaip vadinasi namas, kurį matai paveikslėlyje? Į langelius įrašyk trūksta-
mas raides.



2. Nuspalvink: **i** **l** **t** **k**.



3. Padėk mažyliams grįžti namo. Kodėl jų namai skirtingi?



4. Nurašyk paveikslėlių pavadinimus.



5. Pabaik piešti namus.





6. Nuspalvink tik tuos laukelius, ant kurių parašyti žodžiai su **i** arba **l**.

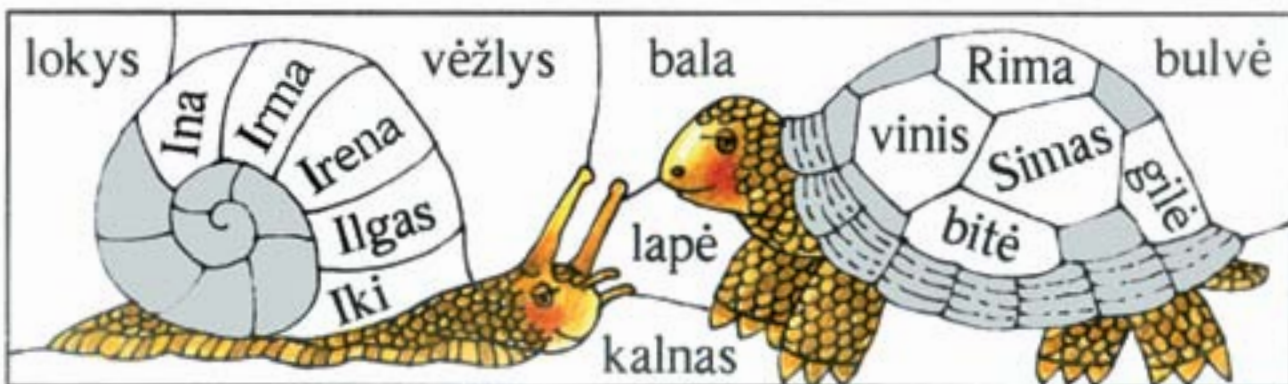

ž Ž



1. Nupiešk tiek žvaigždučių, kiek žodyje yra garsų. Apibrėšk žvaigždę, žyminčią garsą ž.

ž Ž

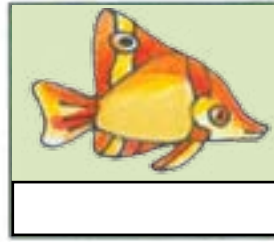

2. Pasimokyk rašyti raides, skiemenis ir žodžius.

ž Ž

ž Ž

ža žu žė až Ža Žė Žu

žvakė Živile



3. Perskaityk skiemenis. Sudaryk žodžius. Mėlynai pabrauk Ž ir ž.



4. Nurašyk žodžius su Ž ir ž.

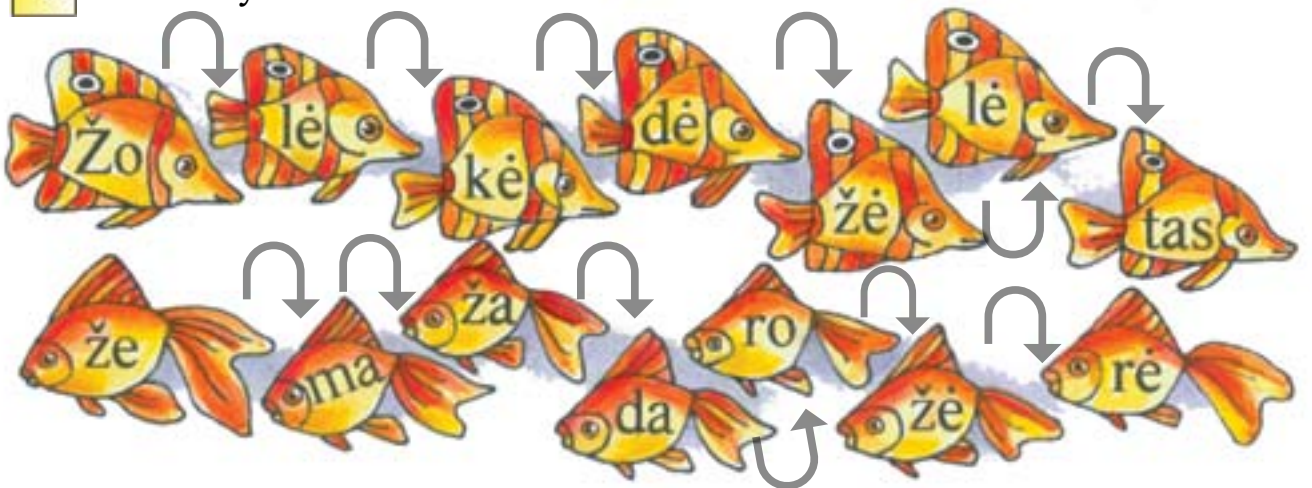



1. Sujunk apšvietimo būdus nuo seniausių iki dabartinių.



2. Pasistenk labai gražiai parašyti raides ir sakinį.

ž Ž
 Maža Živilė dažė dėžes.



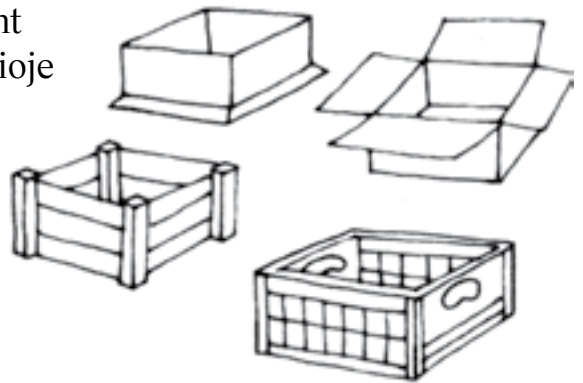

3. Kokia spalva Živilė dažė dėžes? Tariant šios spalvos pavadinimą, žodžio pradžioje girdėti garsas ž. Nuspalvink dėžes ta spalva.



4. Nuvesk žirgą prie ėdžių su žole.



5. Perskaityk ir parašyk jo vardą.

a	n	o	T	c	i	e	k	n	b	ž	s	
ž	ė	r	ū	v	a	D	u					
	L	m	l	p								



6. Iš pabirusių skiemenų sudaryk žodžius ir parašyk juos po atitinkamais paveikslėliais.



7. Pamėgink išspręsti Ramutės Skučaitės galvosūkj.



8. Mėlynai pabrauk visas **Ž** ir **ž**.

Aš – žvaigždė.

Aš nematyta.

Ž-ž-žodžių prirašyta.

Bet... žibėti tegalėsiu,

Kai visus žodžius turėsiu.



	1	ž				
	2	ž				
3		ž				
4		ž				
5		ž				



1. Ką daro šie įrenginiai? Iš raidžių sudaryk žodžius ir parašyk.





2. Ką vakar veikė teta Irena? Perskaityk ir nurašyk sakinį.





3. Sutvarkyk raidžių namus – surask rašytinių ir spausdintinių raidžių poras.





1. Prie paveikslėlių, kuriuose vaikai yra taupūs, nupiešk 😊, o prie tų, kuriuose vaikai neįprato taupyti – 😞.

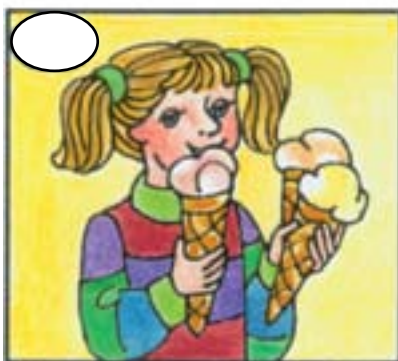

2. Nuspalvink laukelius, pažymėtus raidėmis ž ir Ž. Kam reikalingas šis daiktas?

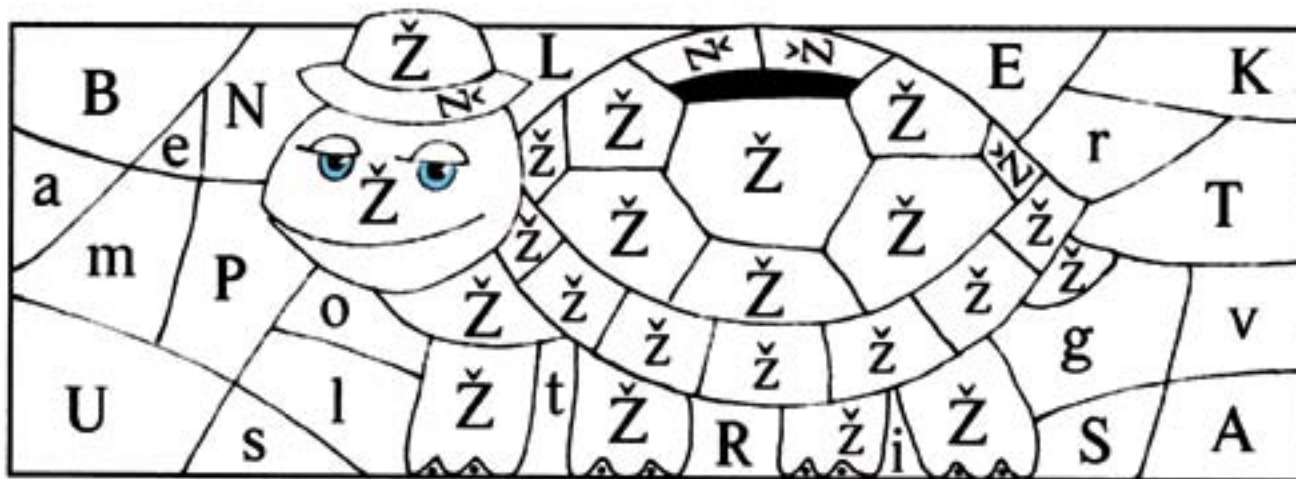

3. Nuspalvink tai, kas daugiau kainuoja.



4. Parašyk nuspalvinto daikto pavadinimą.





1. Senelė, lipdama į dangų, kelią žymėjo pasakos žodžiais. Parašyk tuos žodžius.





2. Sudėliok ant pupos lapus – sudaryk ir parašyk sakinį.